

# Measuring Amplifier DMS 50

**Weight - Force - Pressure - Torque with strain gauges**

## Features

- Bridge sensitivity 0.5 ... 5.0 mV/V
- Tare function (internal/external)
- Teach-In function
- Simulator function
- Min. and max. value storage (not zero-voltage-safe)
- Integrated bridge supply  
2.5 V/5 V/10 V max. 120 mA
- Resolution 16 bit
- Basic accuracy < 0.025 % ±2 Digit
- Isolated analog output 0/4 ... 20 mA; 0/2 ... 10 DC
- Bus connection MODBUS RTU/ASCII RS485/Profibus DP
- Max. 4 alarm outputs, SPDT



Device without  
Fieldbus

Device with  
Fieldbus

## General

The DMS50 converts the output signal of standard strain gauges (DMS measuring bridges) into a standard signal 0/4 ... 20 mA or 0/2 ... 10 DC. The bridge supply and an external control input for the tare function are integrated. If several strain gauges are required in an application, these must be connected parallel. The bridge current must not exceed 120 mA in this case. Where appropriate, a SBB1616 measuring amplifier is to be pre-connected for a feed current up to 200 mA

## Short information

Programming	The device is programmed over frontal membrane buttons, in association with the LCD display.
Teach-In function	From the loading with 2 known weights, the DMS50 calculates the bridge sensitivity of the built-in strain gauge. If several force measuring cells are connected, this is the arithmetic average value of the bridge sensitivities.
Tare function	The indicated value can be set to "0" by button activation or an external control trigger signal. In the configuration level, tare can also be entered directly or determined through input of a known applied load.
Alarm outputs	The alarm outputs can be programmed as max. or min. function. Switch-on delay and switch-off delay time is programmable from 1 s up to 9 h. The switching status is displayed through LED's.
Analog output	An analog output signal 0/4... 20 mA or 0/2 ... 10 V DC is proportionally to the load. it can be programmed within the measuring range of the strain gauge.
Sense connection	With connection of the sense input, the measuring errors arising from line resistances are compensated.



## Connection diagram

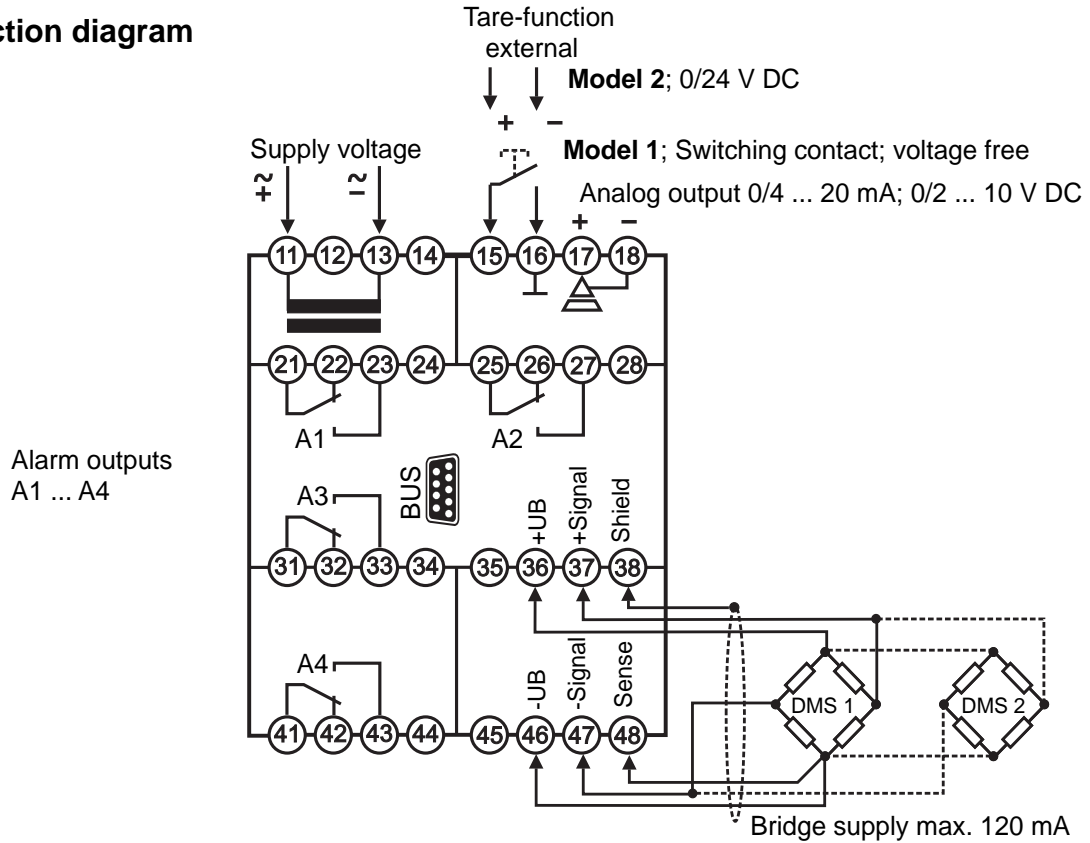

## Dimensions

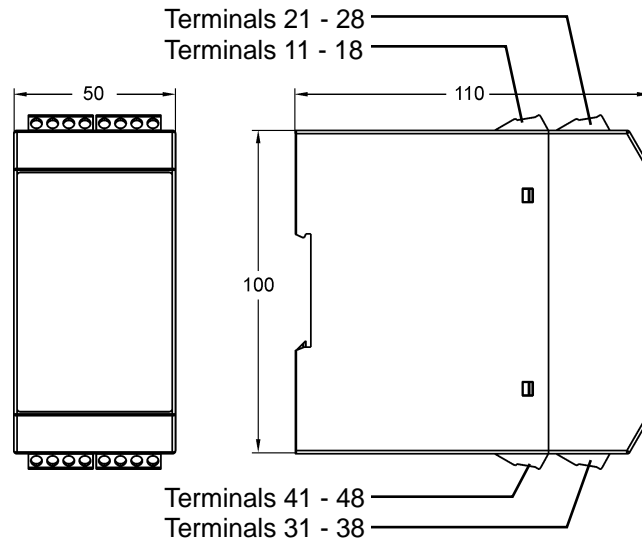

## Bus connection

Modbus		
PIN	Signal	EIA/TIA-485 Name
5	TXD1	B
9	TXD0	A
1	Common	C/C'
Profibus		
3	RxD/TxD-P	
5	DGND	
6	VP/+5V max 10 mA	
8	RxD/TxD-N	

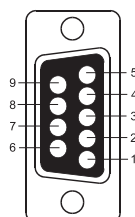

9pole D-Sub socket connector in the front



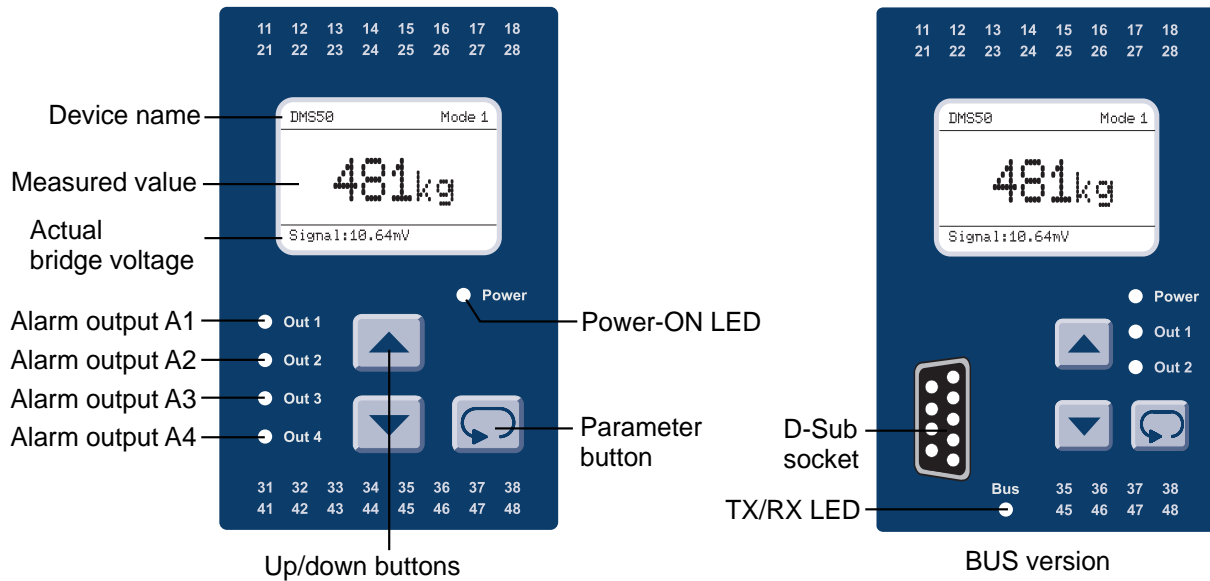



## Controls and indicators





## Description

The operation of the device is implemented in 2 levels. The required parameter is called up with the button . The selection within a parameter and the setting-adjustment of a value is implemented with the buttons  and .

Button combinations (press buttons simultaneously):

-  +  1 parameter back
-  +  Parameter is set to "0" or minimum value.

After the switching on the supply voltage, the device initializes itself. In the display the message indicating device type and software version is shown. After the initialization, the device is running in the working level. The peak value storage is called up and the setpoints of the alarm outputs can be programmed.

The configuration level is called up by activation of the button  for 2 seconds. In this case, all parameters which determine the properties of the device are programmed. After the last menu item, or if no button is pressed for longer than 2 minutes, a skip-back into the working level is implemented automatically and the current measured value is indicated in the display. The configuration level can be exited at any time by holding down button  for 2 seconds.

## Error reports

In case of occurring faults, the messages are shown on the display in plain text. This simplifies location of the error. See explanation page 11.

## Operational startup reference!

The device is preset with an ex-works default setting. Therefore it must be adapted to each special application. See Page 6.

## Note on the representation



Parameter appears only with corresponding configuration



Parameter appears only with corresponding equipment version

## Working level

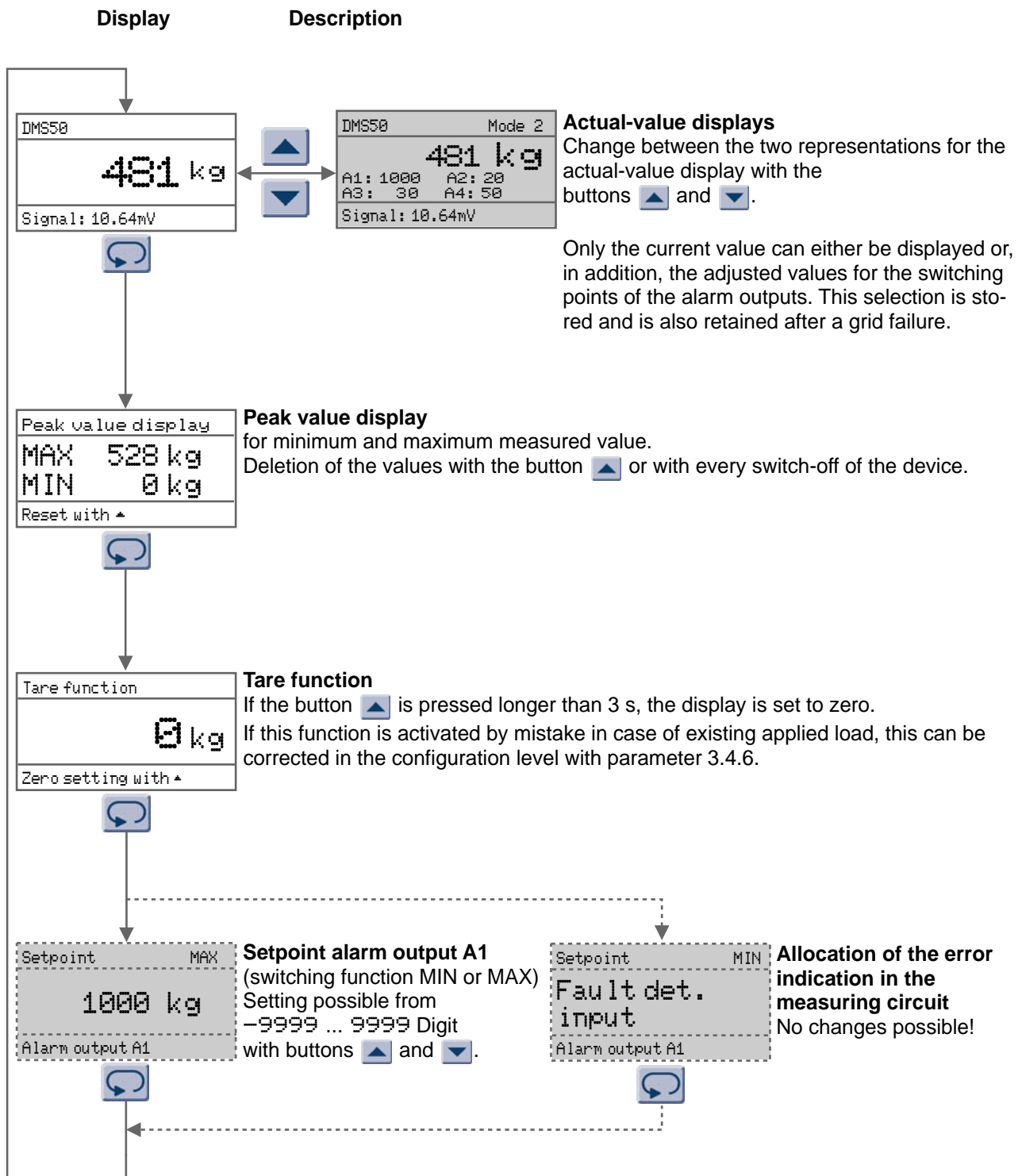

**Note:** Setpoints for alarm outputs A1 ... A4 have to be configured in the same way.

## Configuration level

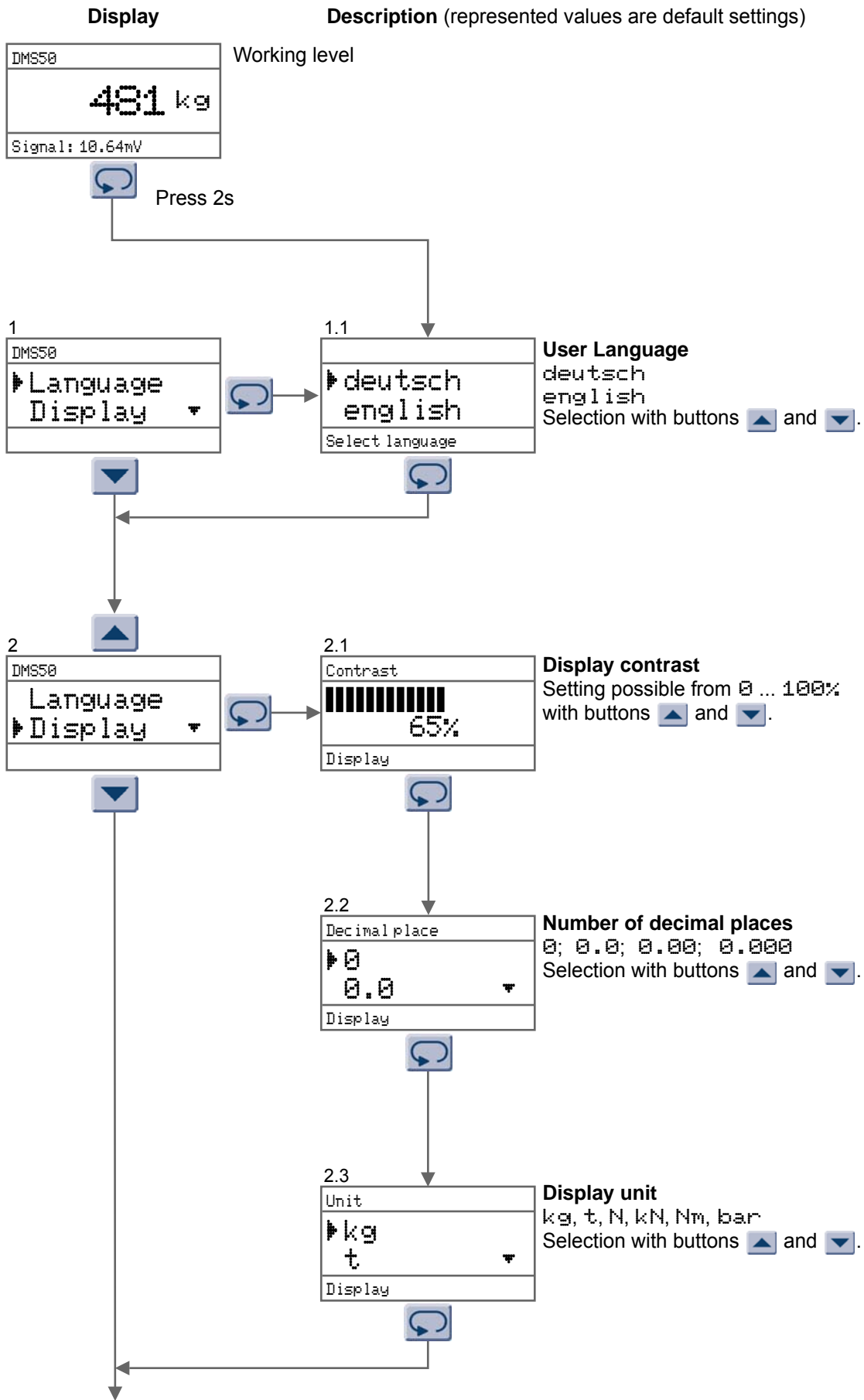



**Display**

**Description** (represented values are default settings)

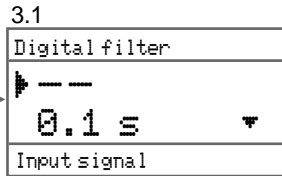
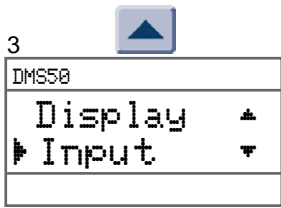

**Digital filter**  
 -- (off) / 0.1 / 1 / 5 / 10 / 20 / 40s  
 Selection with buttons ▲ and ▼.

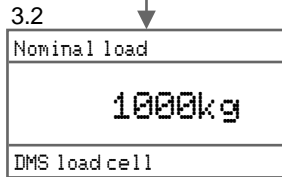

**Nominal load of the DMS-load cell**  
 Setting possible from 1 ... 9999 Digit  
 with buttons ▲ and ▼.  
 If the load is distributed on several (similar) DMS  
 measuring bridges, the sum of the rated loads is to  
 be entered.

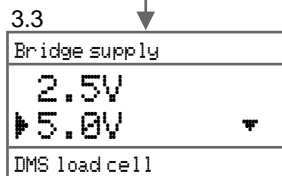

**Select bridge supply**  
 2.5V, 5.0V, 10.0V DC  
 Selection with buttons ▲ and ▼.

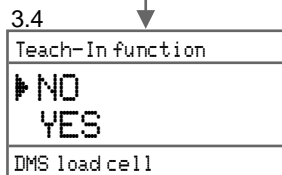

**Teach-In function.**  
 Self-adjusting of the DMS strain gauge with standard  
 weights for the determination of the  
 bridge sensitivity [mV/V].  
 Selection with buttons ▲ and ▼.

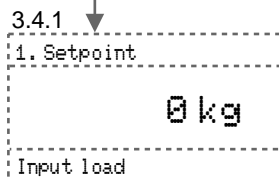

**1. Setpoint m1**  
 Change of the value in the range of the  
 programmed rated load with the but-  
 tons ▲ and ▼.  
 Load DMS bridges(s) with standard  
 weight m1.  
 This parameter is **not** exited automati-  
 cally after 120 seconds.

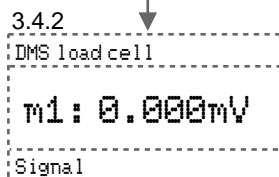

**1. Setpoint**  
 The bridge voltage determined is dis-  
 played after approx. 5 seconds.

continue page 8

Display

Description (represented values are default settings)

3.4.3  
2. Setpoint  
500 kg  
Input load

**2. setpoint m2**

in the range of the programmed rated load with buttons ▲ and ▼. Load DMS-load cell(s) with standard weight m2. This parameter is **not** exited automatically after 120 seconds.

3.4.4  
DMS load cell  
m2: 19.882mV  
Signal

**2. Setpoint**

The bridge voltage determined is displayed after approx. 5 seconds.

3.4.5  
Sensitivity  
2.000mV/V  
DMS load cell

3.4.5  
Sensitivity  
1.988mV/V  
DMS load cell

**Sensitivity** of the DMS load cell.

Setting possible from 0.500 ... 5.000 mV/V with buttons ▲ and ▼.

If the load is distributed on several (similar) DMS measuring bridges, the arithmetic average value of the bridge sensitivity is to be entered.

**Note:** If the Teach-In function has been carried out, the bridge sensitivity calculated by the device is indicated in the display. If this lies outside of the specification, a signal is activated and the value is not stored.

3.4.6  
Input Tare  
41kg  
440kg  
Applied load

With buttons ▲ and ▼, the known tare (upper line in the display) or the known applied load (lower line) can be entered. Both values are dependent on each other and give in sum the total load of the DMS measuring bridge.

Continue page 9

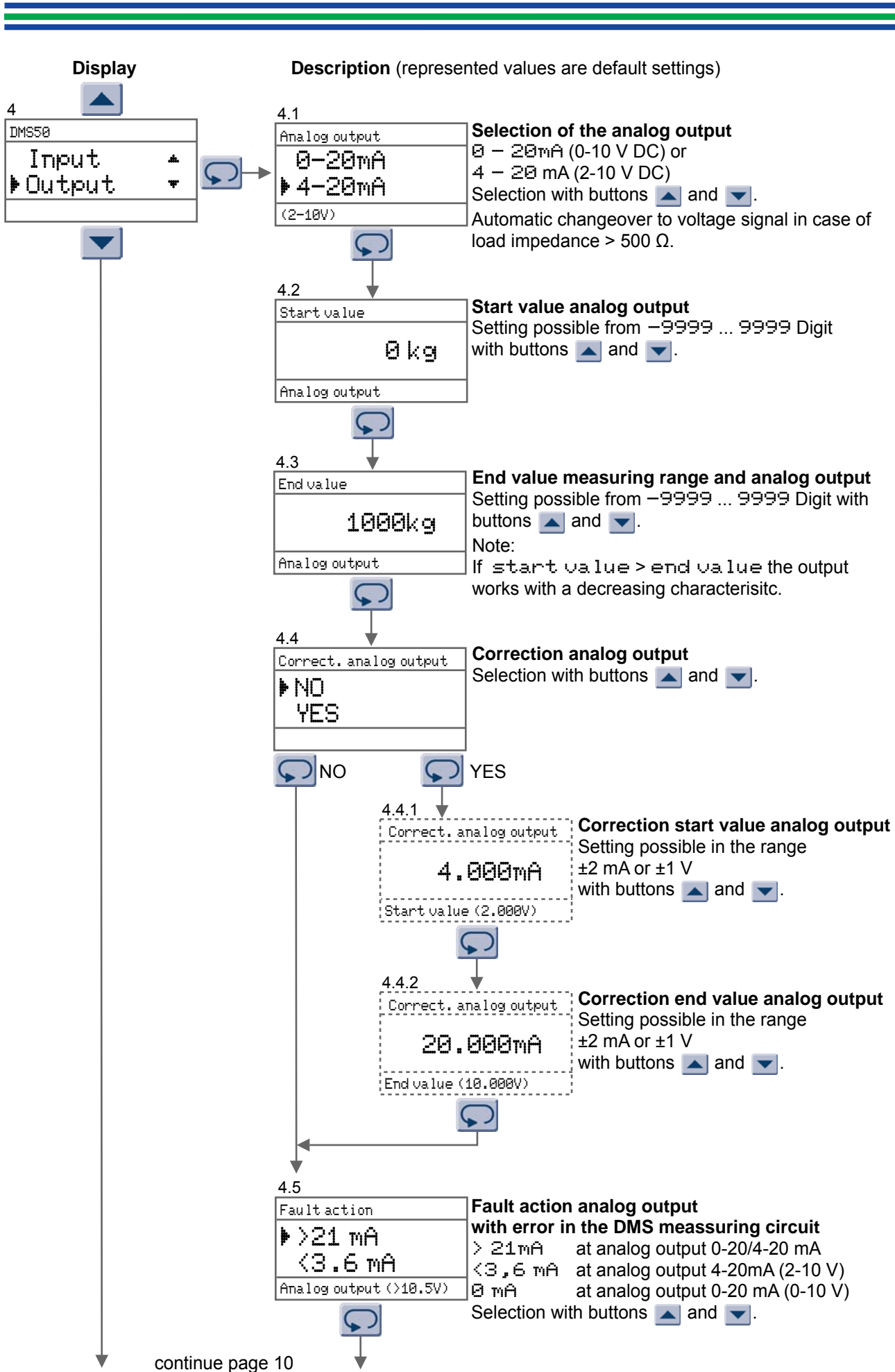

Display

Description (represented values are default settings)

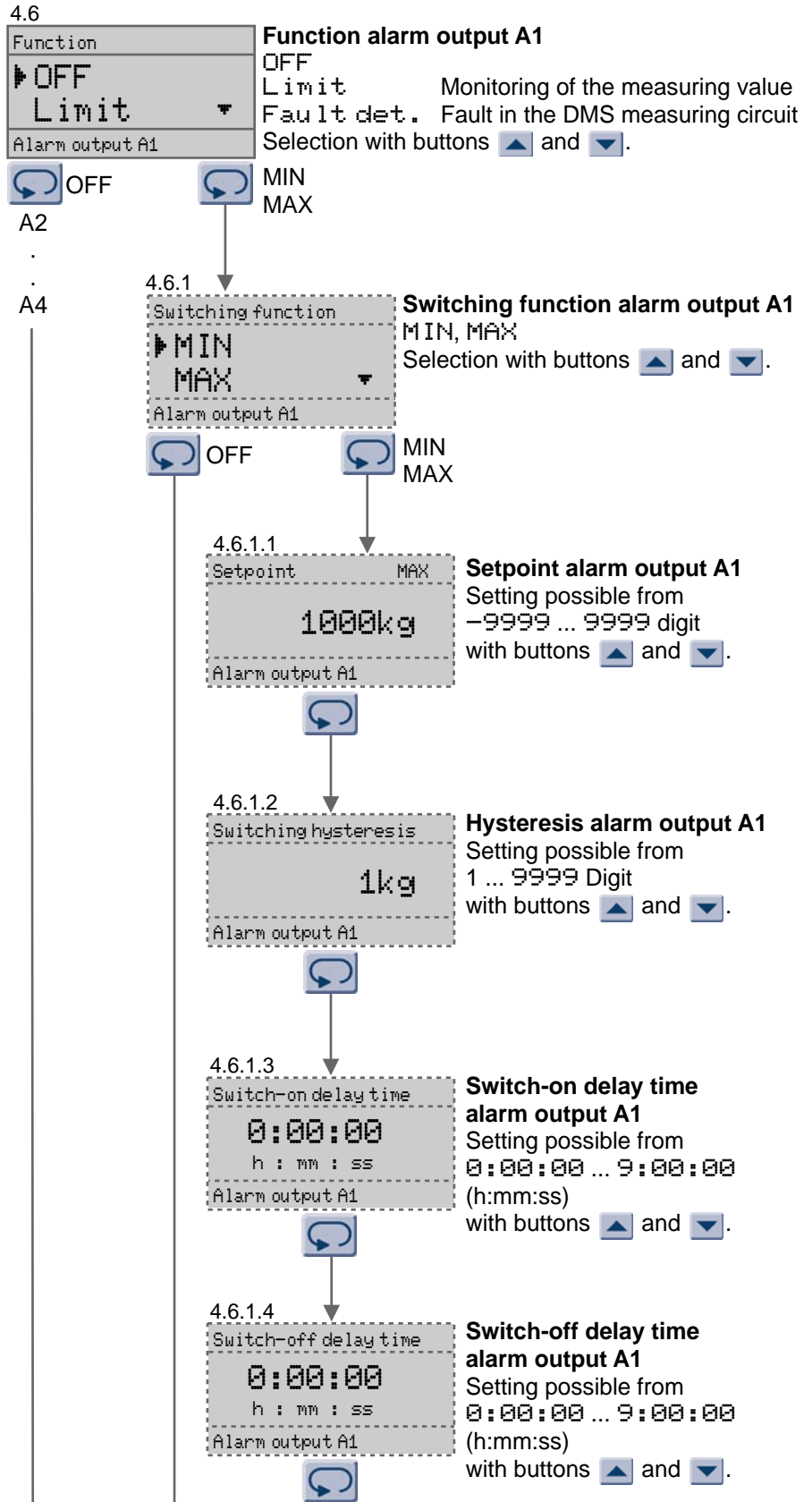

**Note:**

The parameter settings for A2-A4 have to be configured the same way.

continue page 11

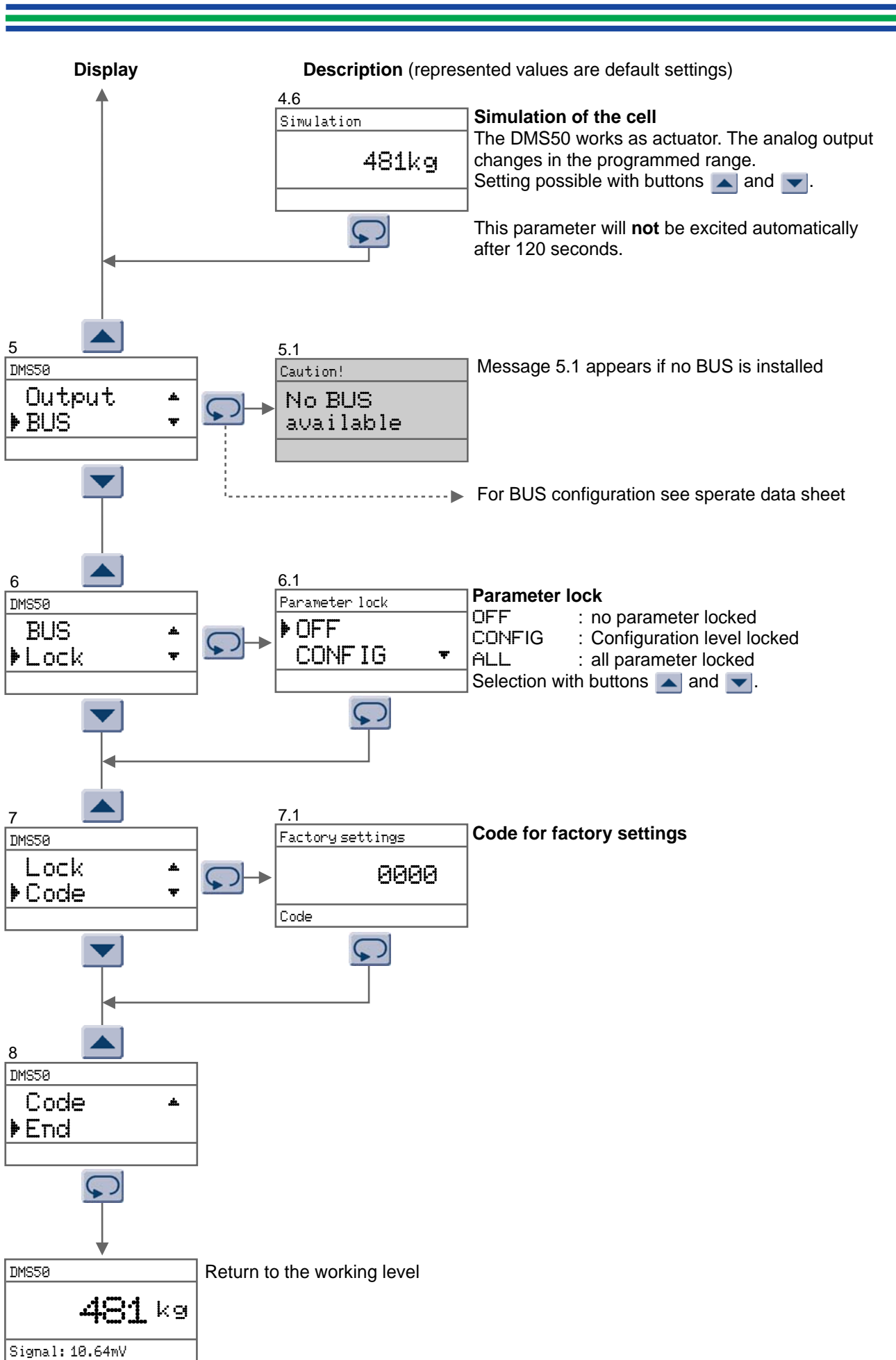

## Error reports

## Explanation

Caution!
Parameter lock
switched on

The parameter can not be changed, since the parameter lock for the configuration level, or work and configuration level, is switched on.

Caution!
Undervoltage

Supply voltage to low

Caution!
XX parameter error

The device must be checked at works

Caution!	Signal
XX.XXX mV	
Meas. value invalid!	

Signaling voltage of the DMS measuring bridge with matching point m1 or m2 too large.

- Overload or incorrect connection of the DMS measuring bridge

Caution! Sensitivity
X.XXXmV/V
Invalid value!

In case of application of the Teach-In process, the calculated sensitivity is outside of the specification of 0.5 ... 5.0 mV/V.

Possible causes:

- Standard weight difference m1 - m2 too small
- Incorrectly selected rated load of the DMS load cell

Caution!
Error- strain gauge
Check connection

Message in case of non-connected DMS measuring bridge or wire break in the connection line. The message flashes alternately with an overflow indicator. According to error cause, the value is displayed with a positive or negative sign.

Change of decimals?
Some parameters not representable! Adapt parameters automatically?
▲ Yes                      ▼ No

Change of decimal places

With the changed number of decimal places, some parameters can be converted, however, not represented!

Selection "No" : Change of the decimal places is not carried out.

Selection "Yes" : Decimal places are changed automatically, where the affected parameters are set to the maximum value. A subsequent verification of the accepted parameters is absolutely necessary.

**Ordering code see last page**







## Ordering code

DMS50 -  1. -  2. -  3. -  4. -  5. -  6.

### 1. Model

- 1 Input load cell,  
input external tare function via voltage free contact
- 2 as befor, but input with isolated external 24 V DC signal

### 2. Alarm outputs

- 00 not installed
- 2R 2 relay outputs A1, A2; relay SPDT

### 3. Alarm outputs/BUS configuration

- 00 not installed
- 2R 2 relay outputs A3, A4; relay SPDT
- MB Modbus RTU/ASCII RS485
- PB Profibus DP

### 4. Analog output

- AO Analog output 0/4 ... 20 mA; 0/2 ... 10 V DC

### 5. Supply voltage

- 0 230 V AC ± 10 % 50-60 Hz
- 1 115 V AC ± 10 % 50-60 Hz
- 5 24 V DC ± 15 %

### 6. Options

- 00 without option

Works configuration according to customer specifications!