

# Monitoring Relay MR 50

Standard signals 0/4 ... 20 mA, 0/2 ... 10 V DC

## Features

- Input standard signals 0/4 ... 20 mA, 0/2 ... 10 V DC
- Measuring range programmable
- Basic accuracy 0.1 % +/- 1 Digit
- Installed units:  
mV, V, mA, A,  $\Omega$ , k $\Omega$ ,  $\mu$ S/cm, mS/cm, °C, °F, min<sup>-1</sup>, rpm,  
bar, mbar, hPa, mm, cm, m, %, °, l, l/min, m<sup>3</sup>, m<sup>3</sup>/h, ppm  
custom units programmable
- Simulator function
- Fault monitoring for break of wire  
in the measuring circuit
- Programmable fault function  
Analog output min. or max. overflow  
Alarm outputs min. or max. function
- Integrated transmitter supply 24 V DC max. 30 mA
- 4 alarm outputs (relay SPDT)
- Isolated analog output 0/4 ... 20 mA; 0/2 ... 10 V DC
- Full 3-port isolation



## General

The Monitoring Relay MR50 has inputs for industry standard signals 0/4 ... 20 mA and 0/2 ... 10 V DC. Measuring value and programmed unit are shown in the display. The integrated transmitter supply offers direct connection of loop powered sensors.

Simple programming, up to 4 alarm outputs (SPDT) and optional available fully isolated free programmable analog output 0/4 ... 20 mA; 0/2 ... 10 V DC meets the demand for different applications. Peak value indication for minimum and maximum measured values are stored in the background and can be read out from the display at any time.

## Short information

Programming	The device is programmed by frontal buttons, in connection with the LCD display.
Inputs	Standard signal 0/4 ... 20 mA and 0/2 ... 10 V DC
Alarm outputs	The alarm outputs can be programmed as max. or min. function. Switch-on delay and switch-off delay time is programmable from 1 s up to 9 h. The switching status is displayed through LED's.
Fault function	A break of wire in the measuring circuit could be monitored. The switching function of the analog and alarm output(s) is programmable in case of an fault.

## Technical data

### Power supply

Supply voltage : 230 V AC  $\pm 10\%$ , 115 V AC  $\pm 10\%$ , or 24 V DC  $\pm 15\%$   
 Power consumption : < 5 VA  
 Operating temperature : -10 ... 55 °C (14 ... 131 °F)  
 Rated voltage : 250 VAC acc. to DIN EN 60664-1  
 between input/relay output/analog output/supply voltage  
 degree of pollution 2, overvoltage category III  
 Test voltage : 4 kV DC between input/relay output/analog output/supply voltage

CE -conformity

Standardize IEC61326 05/2004			Result
IEC 61000-4-2 (ESD) IEC 61000-4-3 (E-field) IEC 61000-4-8 (Magnetic field)	Case	4 kV/8 kV contact/air 10 V/m 30 A/m	B A dispensed with
IEC 61000-4-11 (Voltage dip) IEC 61000-4-4 (Burst) IEC 61000-4-5 (Surge) IEC 61000-4-6 (HF current feed)	AC power supply connection	0.5 period, $\pm 100\%$ 2 kV 1 kV L/N, 2 kV L,N/PE 3 V	A A A A
IEC 61000-4-4 (Burst) IEC 61000-4-5 (Surge) IEC 61000-4-6 (HF current feed)	DC power supply connection	2 kV 1 kV L/N, 2 kV L,N/PE 3 V	A A A
IEC 61000-4-4 (Burst) IEC 61000-4-5 (Surge) IEC 61000-4-6 (HF current feed)	Input/output, signal/control	1 kV 1 kV L/N/PE 3 V	A B A
CISPR16-1/16-2	Radiated interference		Passed

### Input

: 0/4 ... 20 mA; 0/2 ... 10 V DC  
 Fault detection : Break of wire in the measuring circuit  
 Input resistance : Current input 10  $\Omega$ , voltage input 10 k $\Omega$   
 Basic accuracy : <0.1 %,  $\pm 1$  Digit  
 Temperature coefficient : 0.01 %/K  
 Transmitter supply : 24 V DC max. 30 mA

### Output

Alarm outputs A1-A4 : Relay SPDT < 250 V AC < 250 VA < 2 A  $\cos\phi \geq 0,3$ , < 300 V DC < 40 W < 2 A  
 Analog output : 0/4 ... 20 mA burden  $\leq 500 \Omega$ ; 0/2 ... 10 V burden  $> 500 \Omega$ , galv. isolated, output changes automatically (burden impedance dependent).

### Fault function

: For break of wire detection  
 → Analog output 0 mA, < 3.6 mA or > 21.5 mA programmable  
 → Alarm output(s) min. or max. function programmable

### Display

: Graphic LCD-Display 128x64 pixels, white background illuminated

### Case

: Polyamide (PA) 6.6, UL94V-0, DIN rail mounting TS 35  
 Weight : approx. 450 g  
 Connection : Screw terminals 0.14 ... 2.5 mm<sup>2</sup> (AWG 26 .. 14)  
 Protection : Case IP30, terminals IP20, German BGV A3

## Connection diagram

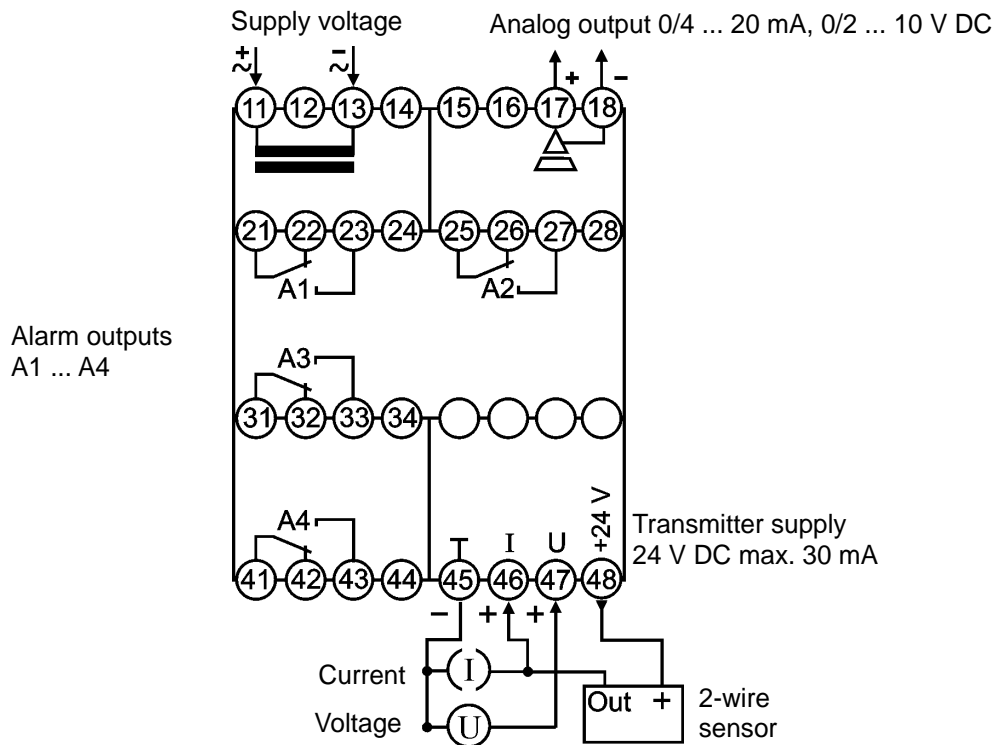

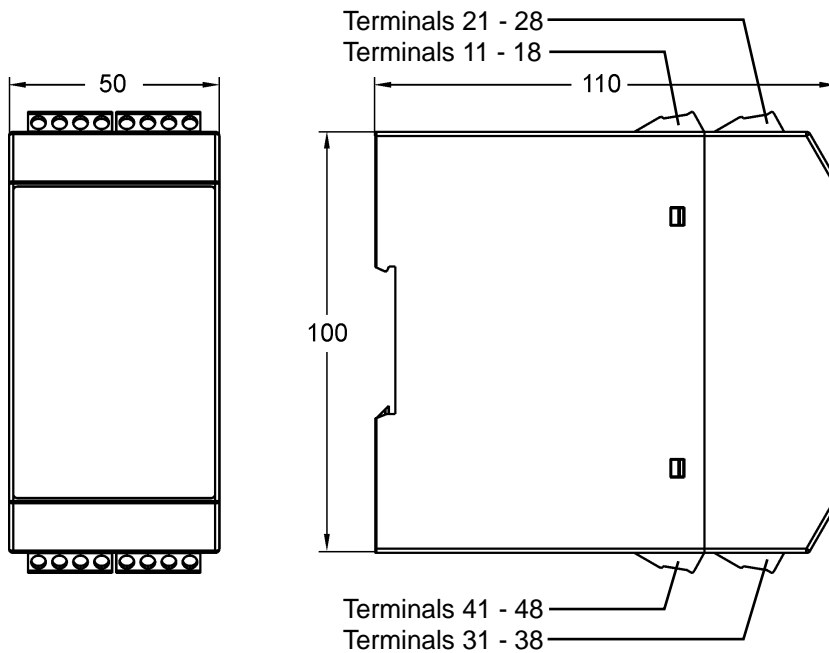

## Dimensions



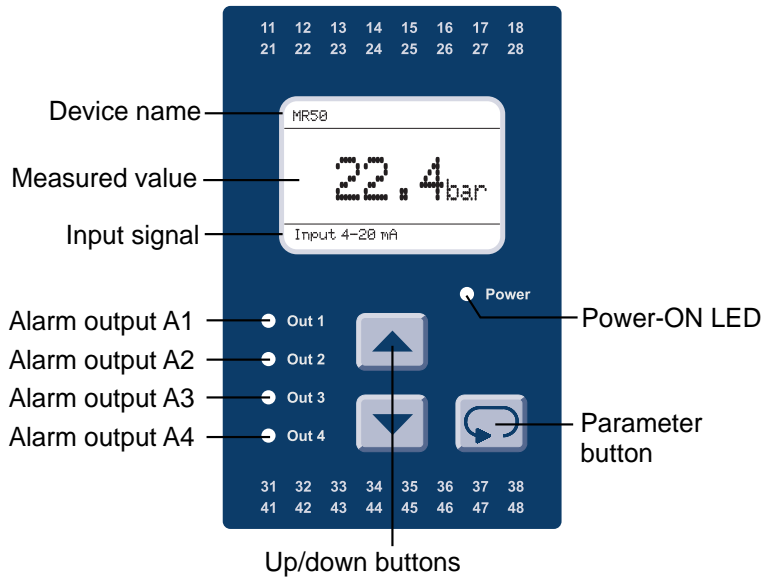



## Controls and indicators





### Description

The operation of the device is implemented in 2 levels. The required parameter is called up with the button . The selection within a parameter and the setting-adjustment of a value is implemented with the buttons  and .

Button combinations (press buttons simultaneously):

-  +  1 parameter back
-  +  Parameter is set to "0" or minimum value.

After the switching on the supply voltage, the device initializes itself. In the display the message indicating device type and software version is shown. After the initialization, the device is running in the working level. The peak value storage is called up and the setpoints of the alarm outputs can be programmed.

The configuration level is called up by activation of the button  for 2 seconds. In this case, all parameters which determine the properties of the device are programmed. After the last menu item, or if no button is pressed for longer than 2 minutes, a skip-back into the working level is implemented automatically and the current measured value is indicated in the display. The configuration level can be exited at any time by holding down button  for 2 seconds.

### Error reports

In case of occurring faults, the messages are shown on the display in plain text. This simplifies location of the error. See description page 11.

### Operational startup reference!

The device is preset with an ex-works default setting. Therefore it must be adapted to each special application. See Page 6.

## Note on the representation



Parameter appears only with corresponding configuration



Parameter appears only with corresponding equipment version

## Working level

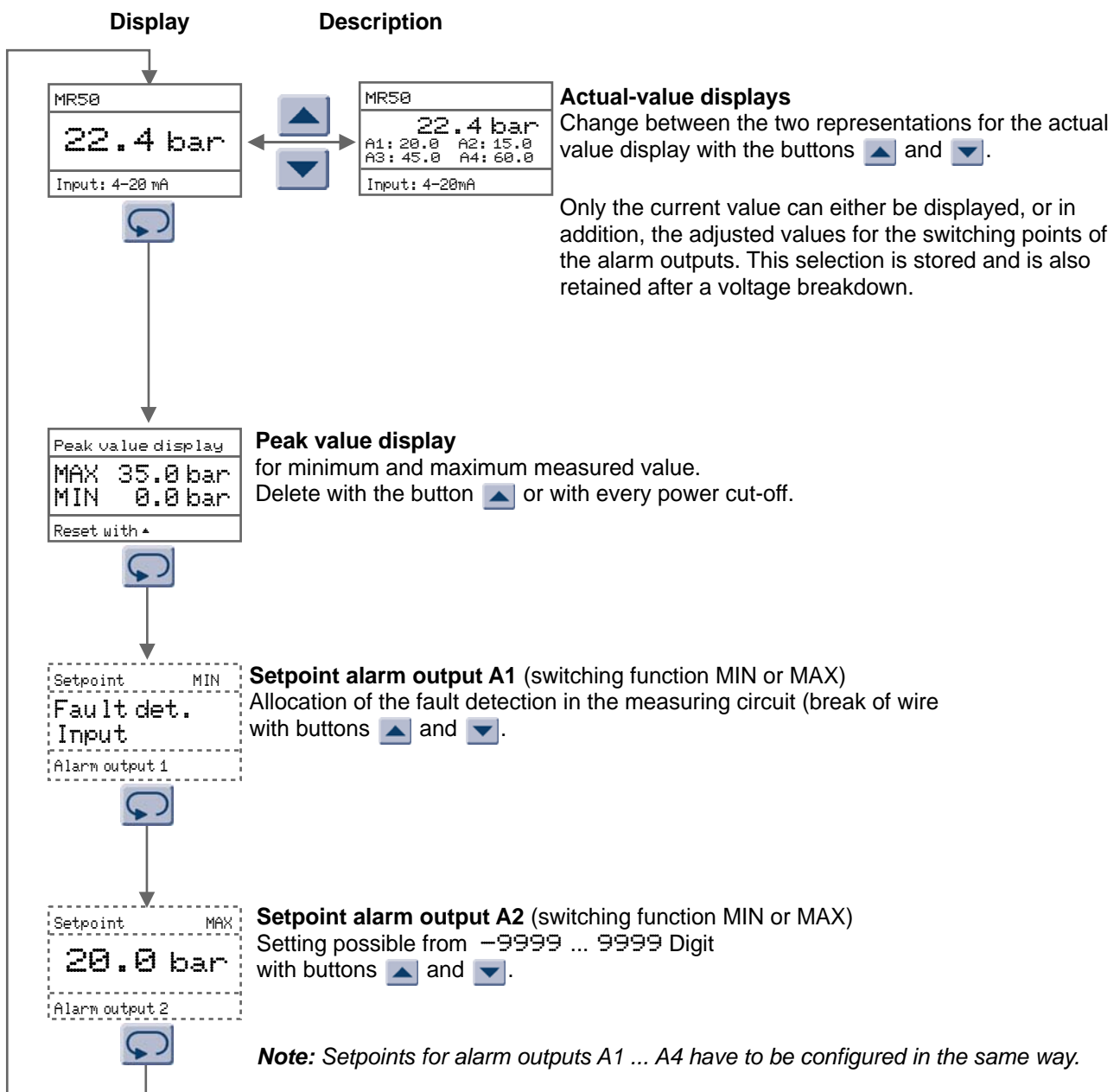

## Configuration level

### Display

Description (represented values are default settings)

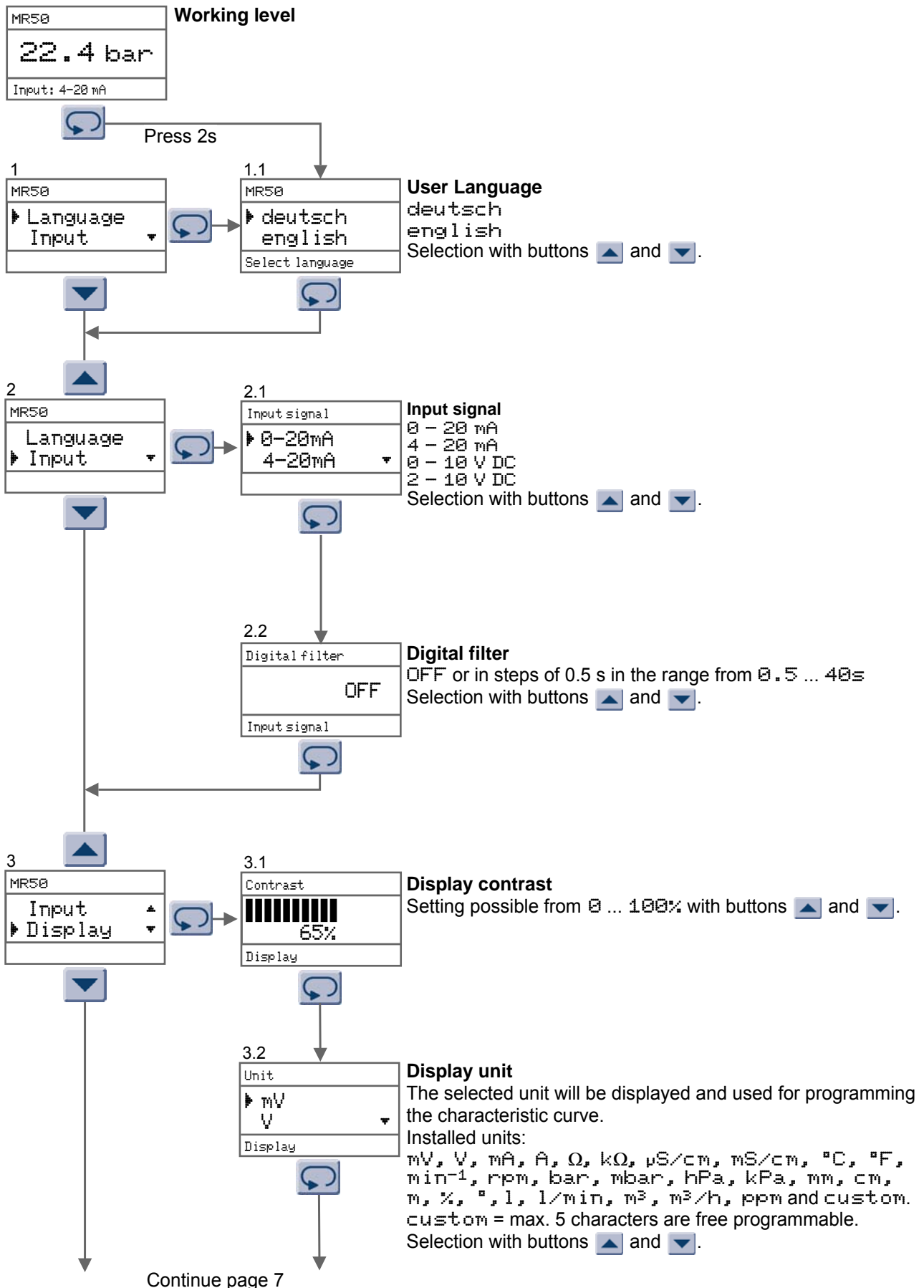



3.3

Custom unit
Unit text
E/h
Display

**Custom unit**

Maximal 5 characters possible (see character set below).

Only appears if `custom` is selected

Scrolling through the characters is possible with buttons ▲ and ▼.

The selected character will be entered with button ↻. After that, the cursor jumps to the next position. Selection procedure as before. If 5 characters are entered or no more character wanted, the parameter `custom unit` will excited automatically.

**Characters:**

- \_ A B C D E F G H I J K L M N O P Q R S T U V W X Y Z
- a b c d e f g h i j k l m n o p q r s t u v w x y z
- ä ö ü ß
- . ? ! , : \_ % / \ + - \* [ ] ( ) < = > " ' ◀ ▶ ▲ ▼ °
- μ Ω Δ 1 2 3 -1 -2



3.4

Decimal place
0
0.0
Display

**Number of decimal places**

0; 0.0; 0.00; 0.000

Selection with buttons ▲ and ▼.



3.5

Start value
0 mV
Display

**Start value for display**

Setting possible from -9999 ... 9999 Digit

with buttons ▲ and ▼.



3.6

End value
100 mV
Display

**End value for Display**

Setting possible from -9999 ... 9999 Digit

with buttons ▲ and ▼.



3.7

Correction
0 mV
Display

**Measured value correction**

Setting possible from -9999 ... 9999 Digit

with buttons ▲ and ▼.



Continue page 8

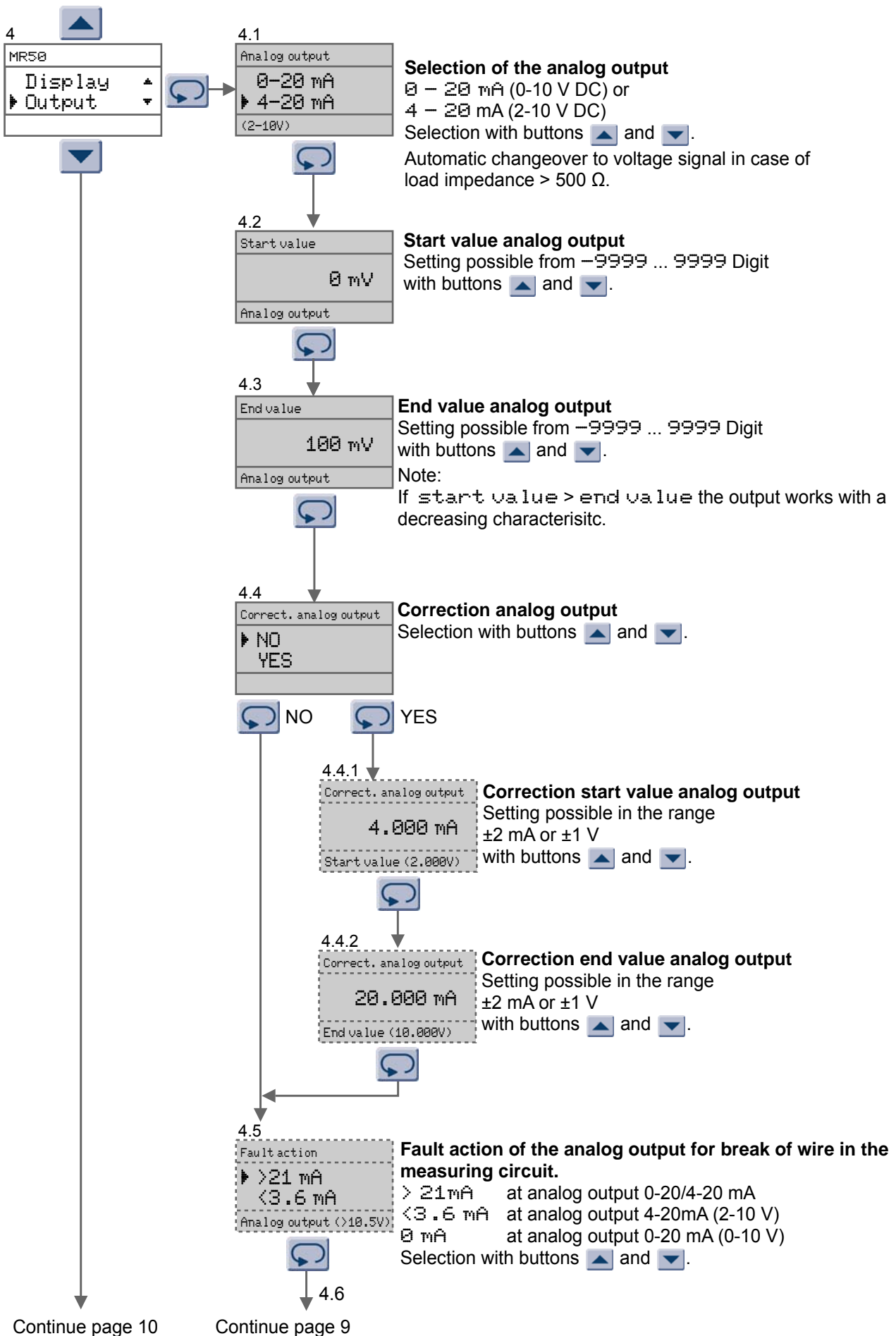

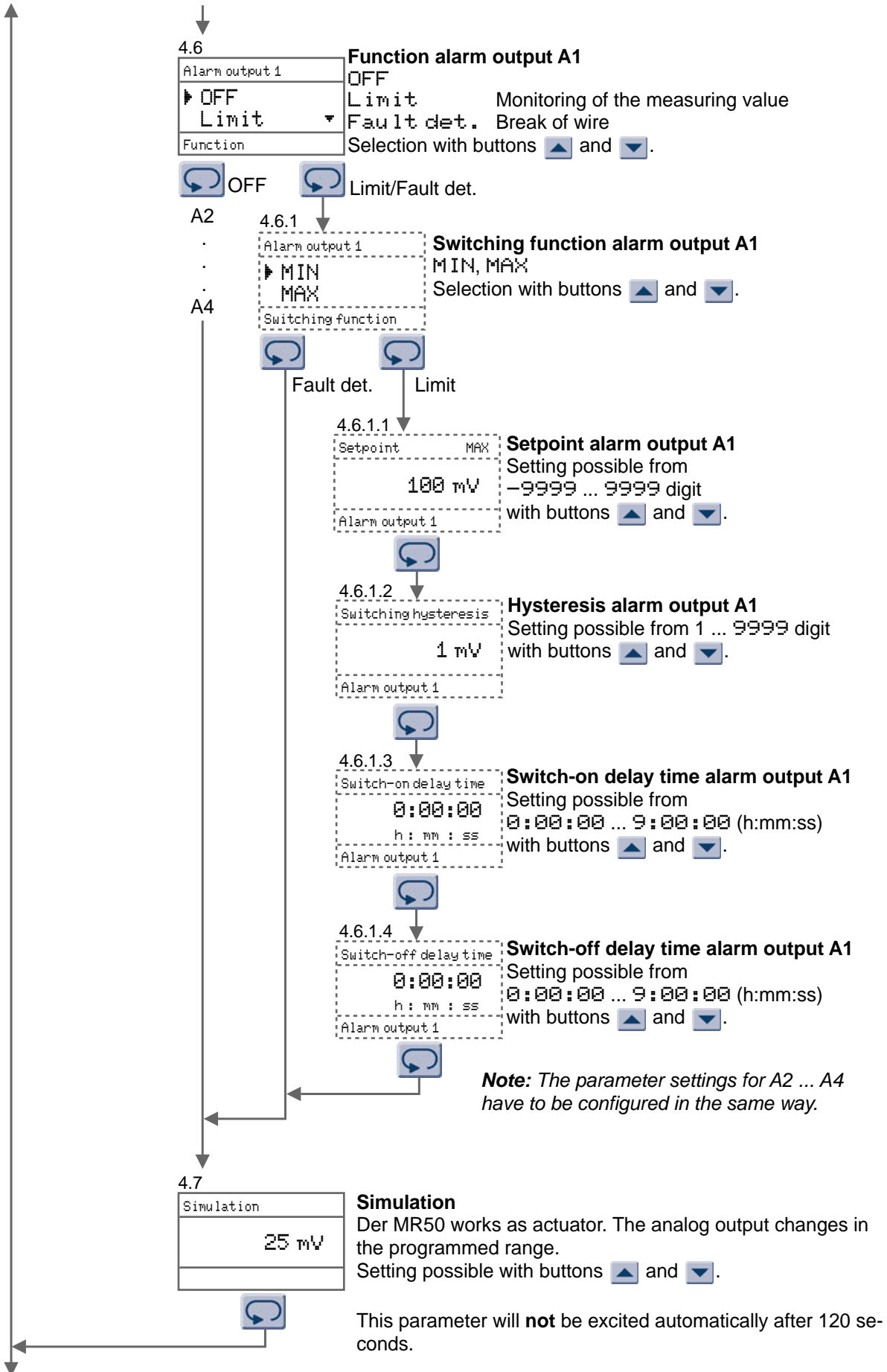

Continue page 10

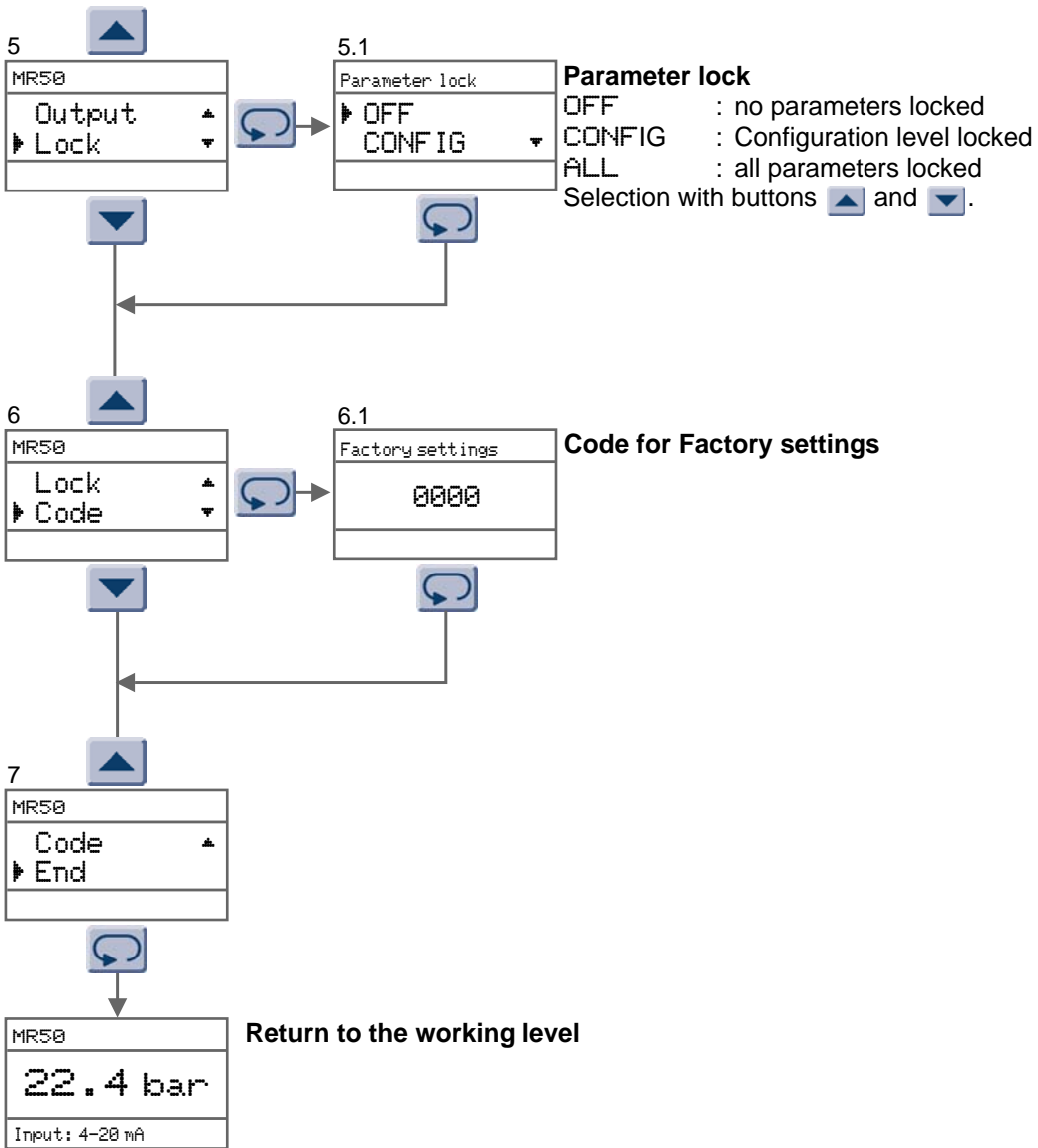



## Error reports

## Description

Caution!
Parameter locked
switched on

The parameter can not be changed, because the parameter lock for the configuration level, or work and configuration level, is switched on.

Caution!
Undervoltage

Supply voltage to low

Caution!
XX Parameter error
Please check

At the check-up of the parameter memory, XX errors are detected. The incorrect parameters are reset to the factory settings. Please check and correct parameters if necessary.

Caution!
XX Parameter error
Calibration necessary

As before, but the factory settings are incorrect. The device must be checked at work.

Change of decimals?
Some parameters not representable! Adapt parameters automatically?
▲ Yes ▼ No

Change of decimal places

While changing number of decimal places, some parameters can be converted, but however, not represented!

Selection "No" : Change of the decimal places is not carried out.

Selection "Yes" : Decimal places are changed automatically, where the affected parameters are set to the maximum possible value. A subsequent verification of the accepted parameters is absolutely necessary.

MR50
Fault input
Input: 9999mV

Break of wire in the measuring circuit.

Text Input: 9999mV is flashing.

## Ordering code

MR50 -  1. -  2. -  3. -  4. -  5. -  6.

### 1. Input

1 Standard signals 0/4 ... 20 mA; 0/2 ... 10 V DC  
Transmitter supply 24 DC V max. 30 mA

### 2. Alarm outputs

2R 2 relay outputs A1, A2 SPDT

### 3. Alarm outputs

00 not installed  
2R 2 relay outputs A3, A4 SPDT

### 4. Analog output

00 not installed  
AO Analog output 0/4 ... 20 mA; 0/2 ... 10 V DC

### 5. Supply voltage

0	230 V AC	± 10 %	50-60 Hz
1	115 V AC	± 10 %	50-60 Hz
5	24 V DC	± 15 %	

### 6. Options

00 without option

Works configuration according to customer specifications.