

Universal controller 5310



DIN-format:

48x96mm

Depth:

112mm

Features

- 2-point-controller
- 3-point-controller
- 3-point-step-controller
- Continuous-temperature controller
- Input RTD sensor, thermocouple, 0...10V or 0/4...20mA
- Break protection
- Measuring range programmable
- Display °C or °F programmable
- PID-controller
- Auto-tuning feature
- Control output relay SPDT, bistable 0/18VDC for SSR-drive, continuous is determined automatically 0/4...20mA burden $\leq 500\Omega$, 0/2...10V $\geq 1k\Omega$ depends on load
- Alarm output programmable
- 2nd setpoint switch selectable
- Serial interface RS485
- Supply voltage 230VAC or 24V DC
- Screw terminals

Contents	Page
-----------------	-------------

Type code	3
Connection diagram	3
Installation instructions	4
Technical data	5
Display and keyboard	7
Adjustment of parameter values.....	8
Function levels	8
Configuration level.....	10
Parameter level	17
Operating level	22
Hints for using the serial interface	24
Process value output (as casting-device).....	25
Error messages	26
Accessories (to be ordered separately).....	26
Parameter list	27

Please read this operating manual carefully before starting up.

Observe the installation and connecting instructions.

Type code

53x0 - 10 - 9 - x11 - x - xx

.	.	.	.	
.	.	.	00	Without interface
.	.	.	40	Serial interface RS485
.	.	.	.	
.	.	7		Power supply: AC 230 V (internal jumper: AC 115 V)
.	.	8		Power supply: DC 24 V
.	.	.		
.	.	1		OUT 1: Relay and bistab. voltage
.	.	6		OUT 1: Relay and bistab. voltage and continuous output
.	.	.		
1				Format 48 mm x 96 mm, 1/8 DIN
2				Format 96 mm x 48 mm, 1/8 DIN

Connection diagram 5310 / 5320

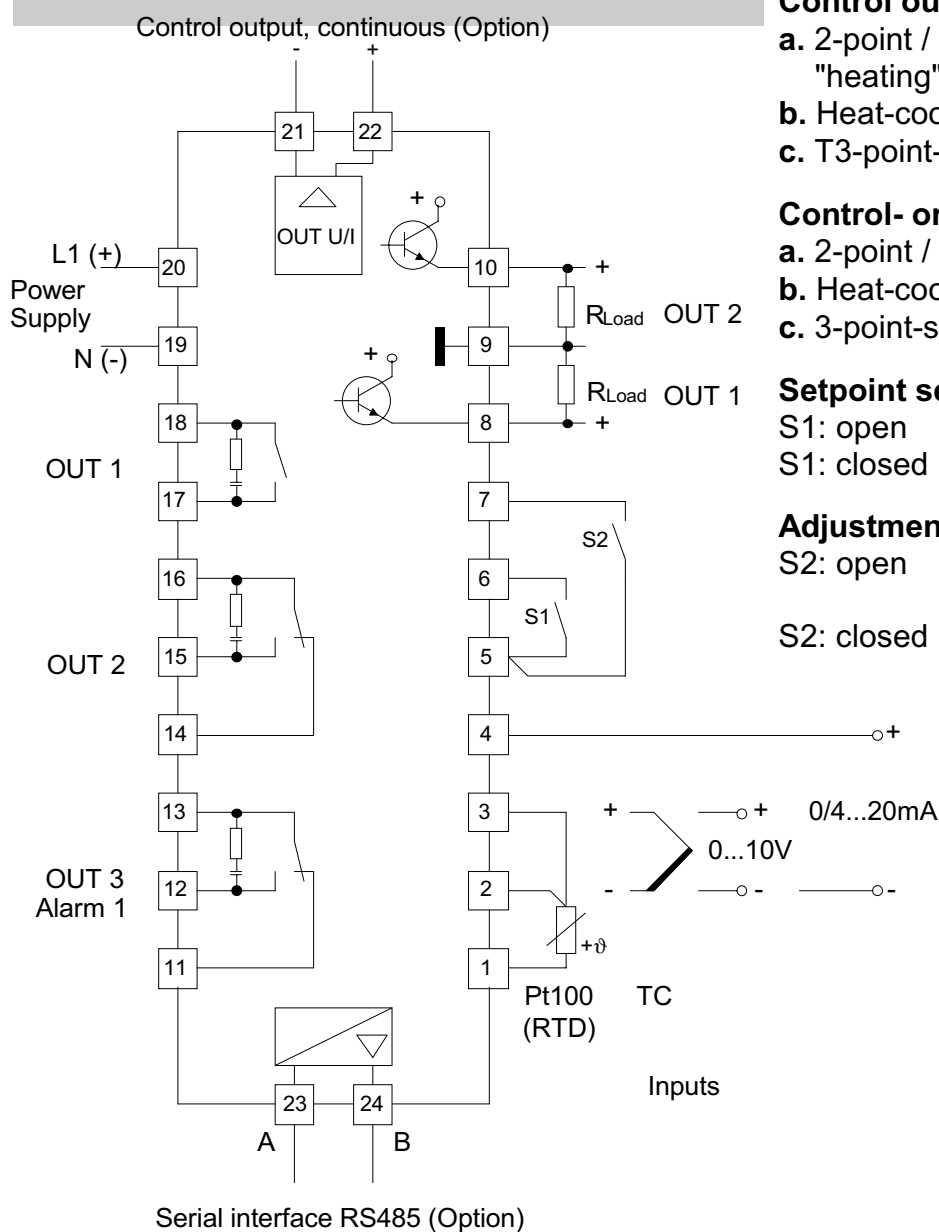

Control output OUT 1

- 2-point / Continuous controller: "heating" or "cooling"
- Heat-cool-controller: "heating"
- T3-point-step-controller: "open"

Control- or alarm output OUT 2

- 2-point / Continuous controller: "alarm 2"
- Heat-cool-controller: "cooling"
- 3-point-step-controller: "close"

Setpoint setting

- S1: open = SP1 valid
 S1: closed = SP2 valid

Adjustment lock (LOC)

- S2: open = Adjustment lock only via "software code"
 S2: closed = Adjustment locked (according to the chosen software code)

Important: It is not permitted to connect the grounds of the sensor-, bistable voltage- and continuous - outputs with each other!

Installation instructions

Make certain that the devices described here are used only for the intended purpose. They are intended for installation in control panels.

The controller must be installed so that it is protected against impermissible humidity and severe contamination.

In addition, make sure that the permitted ambient temperature is not exceeded.

The electrical connections must be made according to the relevant German VDE directives and locally applicable regulations.

Transducer cables and signal lines (e. g. logic output lines) must be laid physically separated from control lines and main voltage supply cables (power cables).

If using a thermocouple sensor, the compensation cables should be laid directly to the controller terminals.

Transducers must be connected only in compliance with the programmed range.

Physical separation between controller and inductive loads is recommended.

Interference from contactor coils must be suppressed by connecting adapted RC-combinations parallel to the coils.

Control circuits (e. g. for contactors) should not be connected to the power supply terminals of the controller.

Important

Before operation, the unit must be configured for its intended purpose (e.g. controller type, sensor type, alarm adjustment etc.).

Please see configuration level.

Device installation

The instrument (5310 / 5320) is constructed with plug-in technology. The instrument can be drawn out of the housing together with the front panel. This, however, can only be done after the instrument has been isolated from its power supply.

Technical data

Inputs:

- **TC:**
Built-in internal compensation point and protection against sensor breakage and incorrect polarity.
Re-calibration not required for a line resistance of up to 50 Ohm.
Calibration accuracy: $\leq 0.25 \%$
- **Pt 100 (RTD):**
2- or 3-wire connection possible.
Built-in protection against sensor breakage and short-circuit.
Maximum permissible line resistance by 3-wire connection: 80 Ohm
Sensor current: $\leq 0.5 \text{ mA}$
Calibration accuracy: $\leq 0.2 \%$
- **Standard signals:**
DC 0 to 20 mA, 4 to 20 mA ($R_i < 10 \text{ Ohm}$)
DC 0 to 10 V, ($R_i > 100 \text{ k-Ohm}$)
Calibration accuracy: $\leq 0.2 \%$

Linear error: $\leq 0.2 \%$
Influence of the ambient temperature: $\leq 0.01 \%$ / K

- **Setpoint switch-over:**
external potential-free contact (switches voltage of app. DC 24 V, max. 1 mA)

Control outputs:

- **OUT 1:** Relay, (SPST n/o) max. AC 250 V, 3 A at $\cos\text{-}\phi = 1$
and bistable voltage, DC 0/18 V, max. 10 mA, short-circuit proof
- **OUT 2:** Relay, (SPDT) max. AC 250 V, 3 A at $\cos\text{-}\phi = 1$
and bistable voltage, DC 0/18 V, max. 10 mA, short-circuit proof
- **OUT 1:** Continuous (additionally for version -611-)
Output type (current or voltage) is determined automatically, dependent on load.
DC 0/4 to 20 mA (load of $\leq 500 \text{ Ohm}$)
DC 0/2 to 10 V (load of $\geq 1 \text{ k-Ohm}$)
Linearity: $< 1,5 \%$
Calibration accuracy: $< 1,0 \%$
Delay time: app. 2 s

Alarm outputs:

- **OUT 2:** Relay, (SPDT) max. AC 250 V, 3 A at $\cos\text{-}\phi = 1$
Only for 2-point-controller (heat-only or cool-only) configuration and continuous-controller configuration.
- **OUT 3:** Relay, (SPDT) max. AC 250 V, 3 A at $\cos\text{-}\phi = 1$

7-Segment-display:

10 mm red (Process)
7,6 mm red (Set)

Data protection:

EAROM

Serial interface:
RS 485 (Option)

EMC:
CE-marked according to EN 50081-2 and EN 50082-2

Power supply:

- **AC 230 V**, (internal jumper: AC 115 V , jumper from "a-b" (230 V) to "b-c" (115 V))
± 10 %, 48 to 62 Hz
Type 5310/5320 : Pull out the device out of the housing together with the front panel.
Type 5350 : Remove rear cover, then pull out half the PCB's by holding the orange plug of the CPU-Board.
The jumper on the powersupply-PCB is now accessible.
- Attention!** This device has to be connected to fused power supply only.

- **AC 24 V**, ± 10 %, 48 to 62 Hz

- **DC 24 V**, ± 20 %, permissible residual ripple max. 5 % r.m.s.

app. 4,5 VA power consumption

Connections:

Screw terminals, Protection mode IP 20 (DIN 40050), Insulation class C (connector / terminal board – 5350)

Permissible operating conditions:

Operating temperature: 0 to 50 °C / 32 to 122 °F
Storage temperature: -30 to 70 °C / -22 to 158 °F
Climate class: KWF DIN 40040;
equivalent to annual average max. 75 % relative humidity.
No condensation.

Casing:

Format: 48 mm x 96 mm (DIN 43700), Installation depth 112 mm (5310)
96 mm x 48 mm (DIN 43700), Installation depth 112 mm (5320)

Panel cutout: 45 mm +0.6 mm x 92 mm +0.8 mm (5310)
92 mm +0.8 mm x 45 mm +0.6 mm (5320)

Unit: replaceable from front (5310, 5320)
Material: Noryl, self-extinguishing, non-drip, UL 94-V1
Protection mode: IP 20 (DIN 40050),
IP 54 front side

Weight:

app. 450 g (5310)
app. 450 g (5320)

Subject to technical improvements!

Display and keyboard

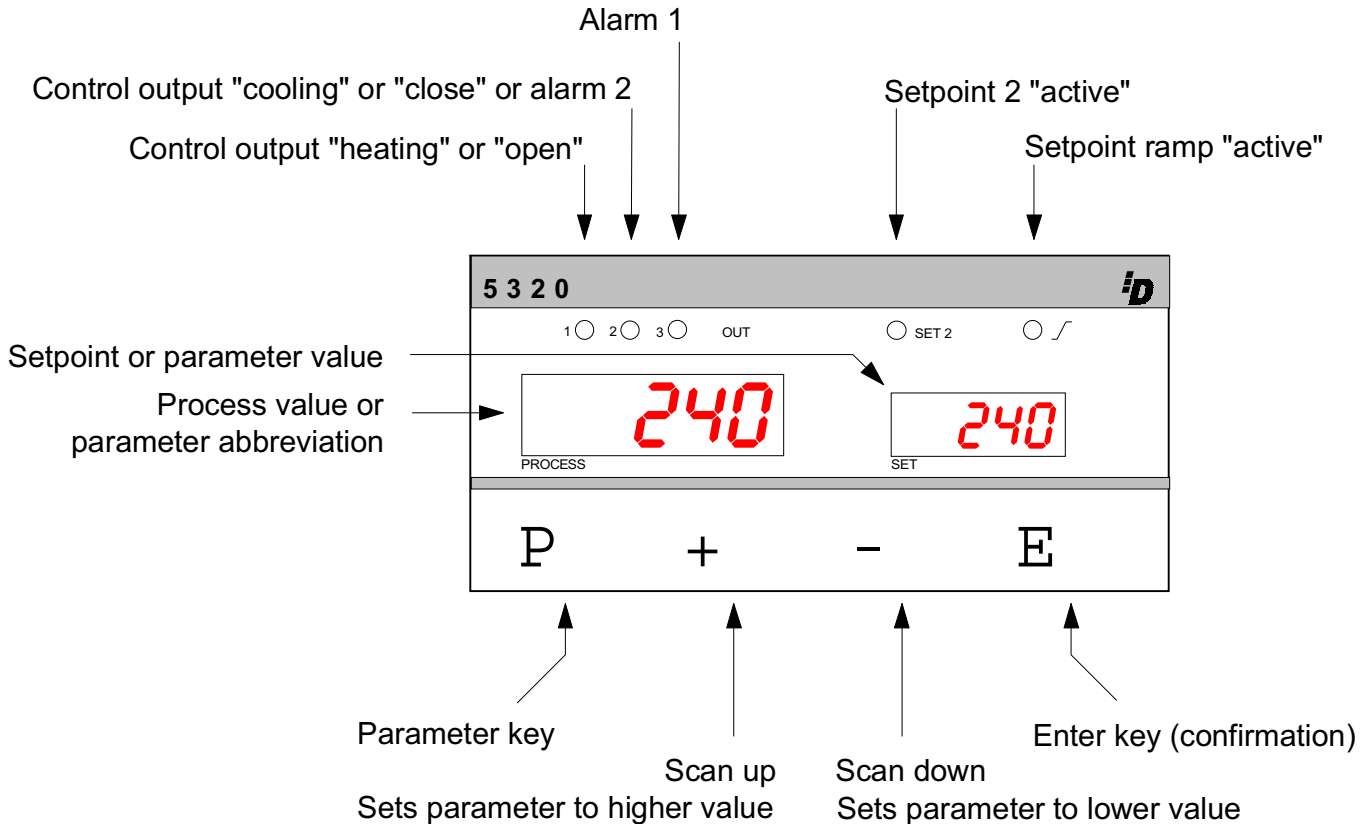
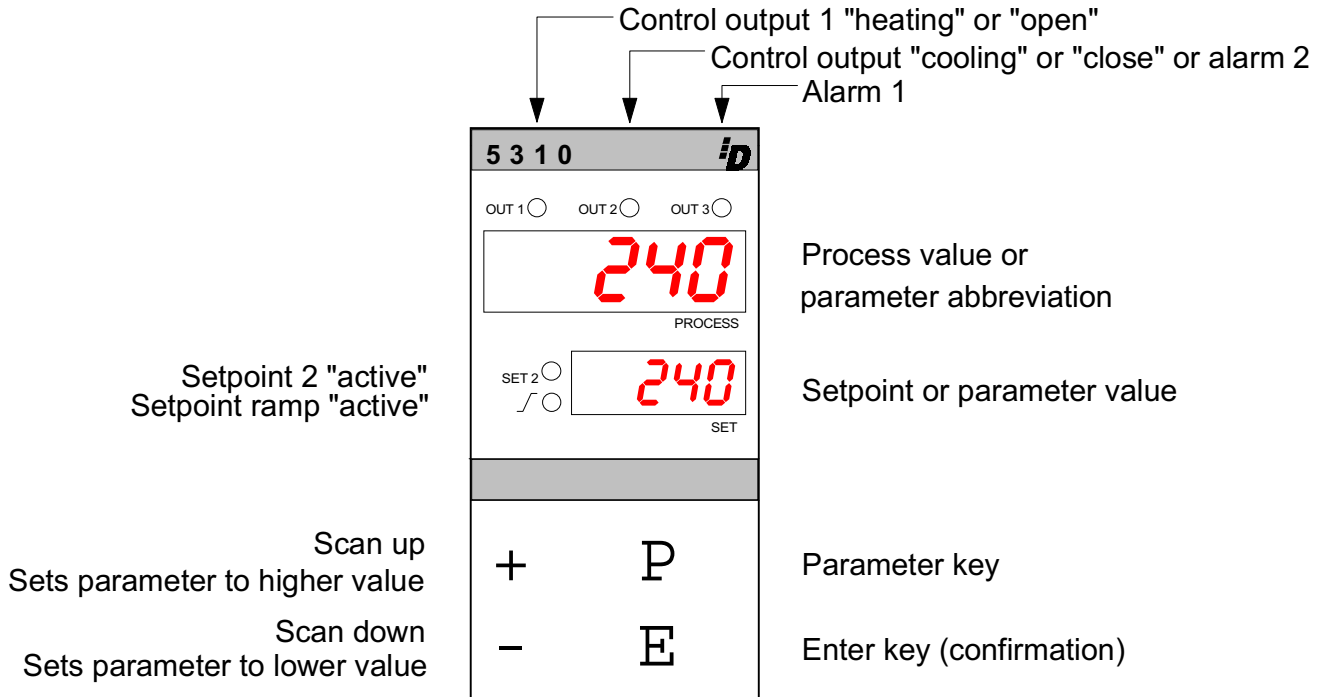

Adjustment of parameter values

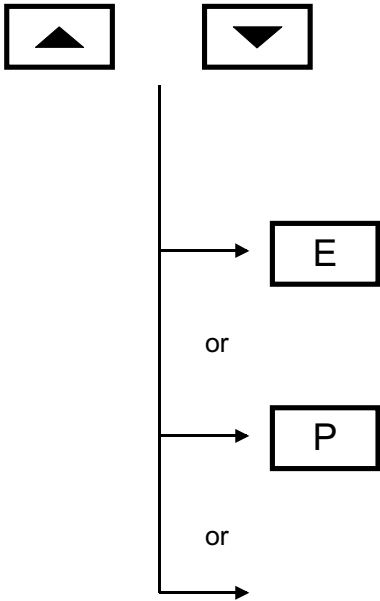

Adjustment of chosen parameter to lower or higher setting. Short operation = single-step adjustment, longer operation = quick-scan. When the parameter adjustments have been altered but not entered, the display will flash bright/dark.

Confirmation of the pre-selected value and storage with powerfail protection. Four decimal points appear briefly as a control of this function.

Sets the parameter back to the originally stored value.

Any alteration made to the parameter, that is not confirmed (Enter key) within approx. 30 seconds, is not accepted and the parameter returns to its originally stored value.

Function levels

The operation of the controller is divided into three levels.

- **Operating level**
- **Parameter level**
- **Configuration level**

Two seconds after switching on the unit, the controller is automatically in the operating level.

Within the **operating level** the set-points, the set-point ramp and the alarm values can, in succession, be displayed by pressing P and adjusted by pressing the + and - keys.

Within the **parameter level** the values are adjusted to suit each individual process. This level is reached by simultaneously pressing the P and E keys.

Within the **configuration level** the controller type, input type, range, alarm behaviour and output type can be pre-selected. This primary information has to be entered before taking the controller into operation. The configuration level is reached by simultaneously pressing the P and E keys for a period of approx. 5 seconds.

The display of each single parameter within the parameter and configuration levels, and their adjustment, are made in the same fashion as within the operating level. After either pressing the E key for approx. 1 second, or waiting for a period of approx. 30 sec., the unit returns automatically to the operating level (display of process and set-point values).

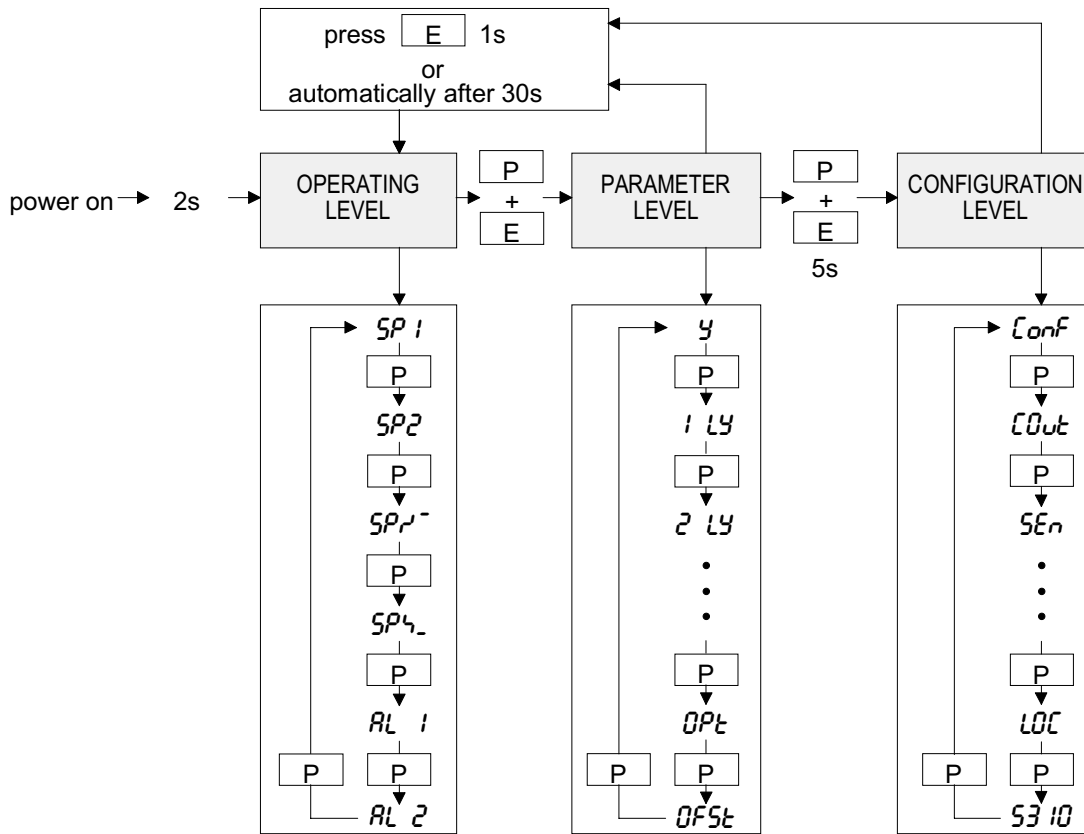

The values on the following pages, included in braces, apply only to controllers equipped with a serial interface. For more details look at the separate interface description.

Configuration level

Display "Process"	Parameter	Display "Set" [ex works]
CONF	Controller configuration { 80H, 8H, r/w }	2P h 2-point (heat-only) controller or continuous controller (heating mode)
		2P c 2-point (cool-only) controller or continuous controller (cooling mode, invers)
		2P n c 2-point (cool-only) controller or continuous controller (cooling mode) with non linear cooling
		3P Heat - off - cool - controller
		3P n c Heat - off - cool - controller with non linear cooling
		3P 5 t Three-point-step-controller: open - neutral - close

Non-linear cooling :

Cooling action can be pre-selected with either linear or non-linear response curve (e.g. for vapour cooling).

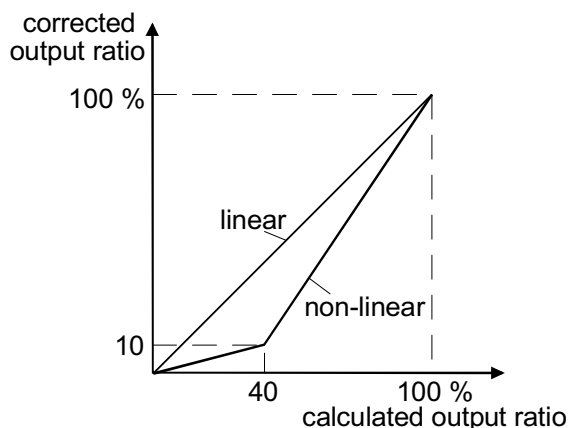

Display	Parameter	OUT 1 (Control output) and OUT 2 (Control output or alarm output A2)
OUT	Configuration of { 81H, 8H, r/w }	OUT1: OUT2:
		1r2r Relay Relay
		1b2r Bistable Relay
		1c2r 0 to 20mA/0 to 10V Relay
		1c.2r 4 to 20mA/2 to 10V Relay
		1r2b Relay Bistable
		1b2b Bistable Bistable
		1c2b 0 to 20mA/0 to 10V Bistable
		1c.2b 4 to 20mA/2 to 10V Bistable
		1r2c Relay 0 to 20mA/0 to 10V
		1r2c. Relay 4 to 20mA/2 to 10V
		1b2c Bistable 0 to 20mA/0 to 10V
1b2c. Bistable 4 to 20mA/2 to 10V		

Configuration level

Display "Process"	Parameter	Display "Set" <i>[ex works]</i>	
SEn	Input configuration { 1AH, 1H, r/w }	P 1 °C	Pt 100 (RTD), -50,0...100,0 °C
		P 1 °F	Pt 100 (RTD), -58,0...212,0 °F
		P 2 °C	Pt 100 (RTD), -90,0...205,0 °C
		P 2 °F	Pt 100 (RTD), -130,0...401,0 °F
		P 3 °C	Pt 100 (RTD), -199...100 °C
		P 3 °F	Pt 100 (RTD), -326...212 °F
		P 4 °C	Pt 100 (RTD), 0...400 °C
		P 4 °F	Pt 100 (RTD), 32...752 °F
		P 8 °C	Pt 100 (RTD), 0...800 °C
		P 8 °F	Pt 100 (RTD), 32...1472 °F
		L 4 °C	TC Fe-CuNi (L), 0...400 °C
		L 4 °F	TC Fe-CuNi (L), 32...752 °F
		L 8 °C	TC Fe-CuNi (L), 0...800 °C
		L 8 °F	TC Fe-CuNi (L), 32...1472 °F
		J 8 °C	TC Fe-CuNi (J), 0...800 °C
		J 8 °F	TC Fe-CuNi (J), 32...1472 °F
		t 4 °C	TC Cu-CuNi (T), 0...400 °C
		t 4 °F	TC Cu-CuNi (T), 32...752 °F
		E 7 °C	TC NiCr-CuNi (E), 0...700 °C
		E 7 °F	TC NiCr-CuNi (E), 32...1292 °F
		n 1 °C	TC NiCr-Ni (K), 0...1200 °C
		n 1 °F	TC NiCr-Ni (K), 32...2192 °F
		S 1 °C	TC Pt10Rh-Pt (S), 0...1600 °C
		S 1 °F	TC Pt10Rh-Pt (S), 32...2912 °F
		r 1 °C	TC Pt13Rh-Pt (R), 0...1600 °C
		r 1 °F	TC Pt13Rh-Pt (R), 32...2912 °F
			0 - 20 Current DC 0...20 mA
			4 - 20 Current DC 4...20 mA
			10 d c Voltage DC 0...10 V

If the input configuration is changed, the following parameters are all reset (setting in brackets), and need to be re-adjusted: Set-points (OFF); Ramps (OFF); Alarms (OFF); control sensitivity (0); sensor offset value (OFF); lower set-point limit (min: display range bottom end); upper set-point limit (max: display range top end).

[0 n P	Configuration of compensation point { 03H, 0H, r/w }	int; 0...60 °C	<i>[int]</i>
		int; 32...140 °F	
Adjustment of used compensation point.			
If an external compensation point is in use, the appropriate temperature has to be set here.			
The adjustment has to be made in degree Celsius or in degree Fahrenheit according to the input configuration.			
This parameter is only available if input configuration is a thermocouple sensor.			

Configuration level

Display "Process"	Parameter	Display "Set" <i>[ex works]</i>
-------------------	-----------	------------------------------------

The following parameters are only valid for standard signal inputs (DC 0-20 / 4-20 mA, DC 0-10 V). The difference between the bottom end of the display range and the top end must amount to a minimum of 100 units, and a maximum of 2000 units. By adjustment of one of the above parameters, the other will automatically follow in case of need.

<i>r d P</i>	Decimal points { 1DH, 1H, r/w }	0; 1; 2	[1]
<i>r H i</i>	Display range top end { 1FH, 1H, r/w }	<i>r L o</i> to 9999	[100.0]
<i>r L o</i>	Display range bottom end { 1EH, 1H, r/w }	-999 to <i>r H i</i>	[0.0]
<i>S P H i</i>	Upper set-point limit { 2CH, 2H, r/w }	<i>S P L o</i> to top range end	[400]
<i>S P L o</i>	Lower set-point limit { 2BH, 2H, r/w }	bottom range end to <i>S P H i</i>	[0]

Configuration level

Display "Process"	Parameter	Display "Set" [ex works]	
COA1	Alarm 1 configuration { 34H, 3H, r/w }	OFF	Alarm OFF
		- - - 1	Signal contact (SC) off-on
		- J - 2	Limit contact (LC) off-on
		- n - 3	Limit comparator (LCP) off-on-off
		- - - 4	Signal contact (SC) on-off
		- L - 5	Limit contact (LC) on-off
		- U - 6	Limit comparator (LCP) on-off-on
		- n - 7	Limit comparator (LCP) off-on-off with start-up suppression
<u>Switching behaviour: Alarm output signal contact</u>		<u>Switching behaviour: Alarm output limit contact</u>	
<p>The signal contact is adjusted and displayed relative to the set-point.</p>		<p>The limit contact is adjusted and displayed as an absolute value.</p>	
<u>Switching behaviour: Alarm output limit comparator</u>		<u>Switching behaviour: Alarm output limit comparator + start-up suppression</u>	
<p>The limit comparator is adjusted and displayed relative to the set-point. The selected value is effective below and above the set-point.</p>		<p>The alarm relay of the limit comparator with start-up suppression is activated when the controller is first switched on. It is only then deactivated when the process value has been within, and left, the O.K. zone.</p>	
<p>on: Relay "activated" or bistable voltage output "high" off: Relay "not active" or bistable voltage output "low"</p>			
<p>If a set-point ramp has been programmed, the alarms that are relative to the set-point (signal contact, limit comparator) follow the set-point up the ramp.</p>			
<p>PLEASE NOTE: In case of sensor error the alarms react in the same way as range override. The alarm contacts therefore do not offer protection against all types of plant breakdown. With this in mind, we recommend the use of a second, independent monitor unit.</p>			
COA2	Alarm 2 configuration { 35H, 3H, r/w }	see COA1 (Alarm 1 configuration)	

Configuration level

Display
"Process"

Parameter

Display "Set"
[ex works]

The following parameters apply to heat-only and heat-cool controller configurations.

Soft start (general function):

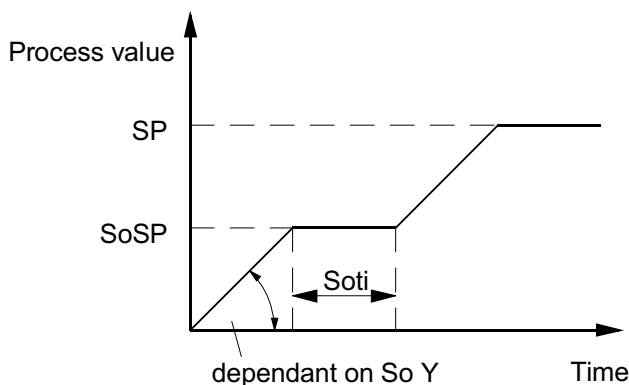

For this purpose the bistable voltage output of the controller must be chosen to actuate SSR relays.

During the soft start the controller's output response is limited to a pre-selected ratio, in order to achieve a slow baking out of high performance heat cartridges.

Simultaneously the output clock frequency is quadrupled. Once the process value reaches the soft start set point, it remains stable at this value for a pre-selected hold-duration time. At the end of this period the process value rises to the valid set-point. This results in a slower, more regular heating period.

If the soft start is active, the controller's autotune function cannot be operated (**Err 7**).

If a set-point ramp has been programmed, the soft start has priority, and the ramp will only become active after the soft start has been completed.

The soft start cannot be selected if the controller is configured as a 3-point step controller.

So Y	Soft start output ratio { 6AH, 6H, r/w }	[OFF] , 10 to 100%; OFF: Soft start inactive, Parameters SoSP and Soti of no importance.
SoSP	Soft start set-point { 6BH, 6H, r/w }	SPLo to SPHi , [0]
Soti	Soft start hold duration time { 6CH, 6H, r/w }	[OFF] , 0.1 to 10.0 min

Configuration level

Display "Process"	Parameter	Display "Set" [ex works]									
<i>H R n d</i>	Manual output ratio { 62H, 6H, r/w }	<i>[OFF], Auto, nAn</i>									
	<p>If manual operation is activated, an "H" is displayed as the first digit in the "set" display, followed by the valid output ratio. This ratio can be manually altered in steps of 1% (+ and - keys). The confirmation succeeds without of E.</p> <p><u>Setting <i>OFF</i></u>: not active (automatic operation).</p> <p><u>Setting <i>Auto</i></u>: In event of sensor break the controller automatically maintains the last valid output ratio as the actuating signal. A few seconds after the sensor break has been rectified, the controller returns to automatic operation and calculates the required output ratio. An additional signal can be issued in the event of sensor break, if the alarm contacts are programmed accordingly.</p> <p><u>Setting <i>nAn</i></u>: The controller now operates only as an actuator; the temperature control is no longer active.</p> <p>Attention! By altering from controller operation to manual operation (Setting <i>Auto</i> or <i>nAn</i>) the controller maintains the last valid output ratio as the actuating signal. Under the following circumstances, the output ratio is 0 %: - if the output ratio at time of sensor break was 100 % - if the controller is working along a set-point ramp; - if the control deviation was more than 0.25 % of the total range at the time of sensor break; - if $Xp = 0$; - if the soft start was active at the time of sensor break.</p>										
<i>C o S b</i>	<p>This parameter is only available when the controller is configured as a 3-point step controller. Behaviour in the event of sensor break:</p> <table border="0"> <tr> <td>{ 8AH, 8H, r/w }</td> <td><i>OFF</i></td> <td>OUT 1 + 2 off</td> </tr> <tr> <td></td> <td><i>o u t 2</i></td> <td>OUT 1 off, OUT 2 on</td> </tr> <tr> <td></td> <td><i>o u t 1</i></td> <td>OUT 1 on, OUT 2 off</td> </tr> </table>		{ 8AH, 8H, r/w }	<i>OFF</i>	OUT 1 + 2 off		<i>o u t 2</i>	OUT 1 off, OUT 2 on		<i>o u t 1</i>	OUT 1 on, OUT 2 off
{ 8AH, 8H, r/w }	<i>OFF</i>	OUT 1 + 2 off									
	<i>o u t 2</i>	OUT 1 off, OUT 2 on									
	<i>o u t 1</i>	OUT 1 on, OUT 2 off									
<i>L O C</i>	Security lock { 85H, 8H, r/w }	<table border="0"> <tr> <td><i>OFF</i></td> <td>lock inactive</td> </tr> <tr> <td><i>P L</i></td> <td>parameter and configuration level locked</td> </tr> <tr> <td><i>- S P 1</i></td> <td>all parameters apart from set-point 1 locked</td> </tr> <tr> <td><i>R L L</i></td> <td>all parameters locked</td> </tr> </table> <p>All locked parameters can be selected and read, but not altered. This adjustment cannot be changed if the external switch S2 is closed.</p>	<i>OFF</i>	lock inactive	<i>P L</i>	parameter and configuration level locked	<i>- S P 1</i>	all parameters apart from set-point 1 locked	<i>R L L</i>	all parameters locked	
<i>OFF</i>	lock inactive										
<i>P L</i>	parameter and configuration level locked										
<i>- S P 1</i>	all parameters apart from set-point 1 locked										
<i>R L L</i>	all parameters locked										

Configuration level

Display "Process"	Parameter	Display "Set"																		
		<i>[ex works]</i>																		
The following parameters apply only to controllers equipped with a serial interface.																				
<i>R d r</i>	Unit address { 8FH, 8H, r/w }	1 to 255 <i>[1]</i>																		
	Using this address, a host computer system can communicate with the controller. Every controller must have an individual address. Attention! A maximum of 32 controllers can be connected to a RS485 bus.																			
<i>b R u d</i>	Baud rate { 8DH, 8H, r/w }	<table border="0"> <tr><td><i>0 F F</i></td><td>serial interface is off</td></tr> <tr><td><i>0 3</i></td><td>300 Baud</td></tr> <tr><td><i>0 6</i></td><td>600 Baud</td></tr> <tr><td><i>1 2</i></td><td>1200 Baud</td></tr> <tr><td><i>2 4</i></td><td>2400 Baud</td></tr> <tr><td><i>4 8</i></td><td>4800 Baud</td></tr> <tr><td><i>9 6</i></td><td>9600 Baud</td></tr> <tr><td><i>1 9 2</i></td><td>19200 Baud</td></tr> <tr><td><i>3 8 4</i></td><td>38400 Baud</td></tr> </table>	<i>0 F F</i>	serial interface is off	<i>0 3</i>	300 Baud	<i>0 6</i>	600 Baud	<i>1 2</i>	1200 Baud	<i>2 4</i>	2400 Baud	<i>4 8</i>	4800 Baud	<i>9 6</i>	9600 Baud	<i>1 9 2</i>	19200 Baud	<i>3 8 4</i>	38400 Baud
<i>0 F F</i>	serial interface is off																			
<i>0 3</i>	300 Baud																			
<i>0 6</i>	600 Baud																			
<i>1 2</i>	1200 Baud																			
<i>2 4</i>	2400 Baud																			
<i>4 8</i>	4800 Baud																			
<i>9 6</i>	9600 Baud																			
<i>1 9 2</i>	19200 Baud																			
<i>3 8 4</i>	38400 Baud																			
	The Baud rate displays the data transfer speed, with which one bit is transferred from the transmitter to the receiver. For further details please see the separate interface description.																			
<i>F o r</i>	Data format { 8EH, 8H, r/w }	<table border="0"> <tr><td><i>7 E 1</i></td><td>7 data, even, 1 stop bit</td></tr> <tr><td><i>7 o 1</i></td><td>7 data, odd, 1 stop bit</td></tr> <tr><td><i>7 E 2</i></td><td>7 data, even, 2 stop bits</td></tr> <tr><td><i>7 o 2</i></td><td>7 data, odd, 2 stop bits</td></tr> <tr><td><i>7 n 2</i></td><td>7 data, none, 2 stop bits</td></tr> <tr><td><i>8 E 1</i></td><td>8 data, even, 1 stop bit</td></tr> <tr><td><i>8 o 1</i></td><td>8 data, odd, 1 stop bit</td></tr> <tr><td><i>8 n 1</i></td><td>8 data, none, 1 stop bit</td></tr> <tr><td><i>8 n 2</i></td><td>8 data, none, 2 stop bits</td></tr> </table>	<i>7 E 1</i>	7 data, even, 1 stop bit	<i>7 o 1</i>	7 data, odd, 1 stop bit	<i>7 E 2</i>	7 data, even, 2 stop bits	<i>7 o 2</i>	7 data, odd, 2 stop bits	<i>7 n 2</i>	7 data, none, 2 stop bits	<i>8 E 1</i>	8 data, even, 1 stop bit	<i>8 o 1</i>	8 data, odd, 1 stop bit	<i>8 n 1</i>	8 data, none, 1 stop bit	<i>8 n 2</i>	8 data, none, 2 stop bits
<i>7 E 1</i>	7 data, even, 1 stop bit																			
<i>7 o 1</i>	7 data, odd, 1 stop bit																			
<i>7 E 2</i>	7 data, even, 2 stop bits																			
<i>7 o 2</i>	7 data, odd, 2 stop bits																			
<i>7 n 2</i>	7 data, none, 2 stop bits																			
<i>8 E 1</i>	8 data, even, 1 stop bit																			
<i>8 o 1</i>	8 data, odd, 1 stop bit																			
<i>8 n 1</i>	8 data, none, 1 stop bit																			
<i>8 n 2</i>	8 data, none, 2 stop bits																			
	With this parameter the data format is determined. For further details please see the separate interface description.																			
<i>S 3 1 0</i>	Figure of device family { 01H, 0H, r/w }	- - - - end of the configuration level																		

Parameter level

The following parameters apply to 2-point and heat-cool controller configurations

Display "Process"	Parameter	Display "Set" [ex works]	
<i>y</i>	Valid output ratio { 60H, 6H, r } The output ratio display shows the momentarily calculated output ratio. It cannot be altered. The display is in percent of the installed performance capability for heating or cooling. Output ratio for cooling is shown as a negative value.	-100 to 100 %	
<i>i</i> <i>L</i> <i>y</i>	OUT 1 output ratio limit { 64H, 6H, r/w }	0 to 100 %	[100]
<i>2</i> <i>L</i> <i>y</i>	OUT 2 output ratio limit { 69H, 6H, r/w } (only by heat-cool controller configuration) A limitation of the output ratio is only necessary when: - the heating energy supply is grossly over-dimensioned compared to the power required, or - to turn off a control output (setting: 0 %). Under normal circumstances no limitation is needed (setting: 100 %). The limitation becomes effective, when the controllers' calculated output ratio is greater than the maximum permissible (limited) ratio. Attention! The output ratio limitation does not work during autotuning.	0 to 100 %	[100]
<i>i</i> <i>P</i>	OUT 1 Xp, P-range { 40H, 4H, r/w } If xp = OFF, the next parameter to follow is <i>i</i> <i>5d</i> (control sensitivity).	<i>OFF</i> ; 0.1 to 100.0 %	[3.0]
<i>i</i> <i>d</i>	OUT 1 Tv, Rate { 41H, 4H, r/w }	<i>OFF</i> ; 1 to 200 s	[30]
<i>i</i> <i>J</i>	OUT 1 Tn, Reset { 42H, 4H, r/w } Normally the controller works using PID control action. This means, controlling without deviation and with practically no overshoot during start-up. Control action can be altered in its structure by making the following adjustments to the parameters: a) no control action, on-off (setting: Xp=OFF); b) P-action (setting: Tv and Tn = 0); c) PD-action (setting: Tn = 0); d) PI-action (setting: Tv = 0); e) PID action	<i>OFF</i> ; 1 to 1000 s	[150]
<i>i</i> <i>ε</i>	OUT 1 cycle time { 43H, 4H, r/w } The switching frequency of the actuator can be determined by adjusting the cycle time. This is the total time needed for the controller to switch on and off once. a) Relay outputs: cycle time > 10 s b) Bistable voltage outputs: 0.5 to 10 s	0.5 to 240.0 s	[15.0]

Parameter level

Display "Process"	Parameter	Display "Set" <i>[ex works]</i>	
<i>i S d</i>	OUT 1 control sensitivity Sd { 47H, 4H, r/w }	<i>OFF</i> ; 0.1 to 80.0 <i>OFF</i> ; 0.01 to 8.00 <i>OFF</i> ; 0.001 to 0.800	[0.1] 1) 2)

Adjustment of the control sensitivity, output OUT 1 (only if Xp = 0, no control action).

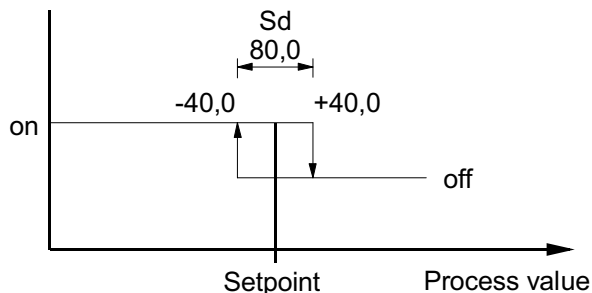

The following parameters apply only to the configuration of heat-cool controllers

Display "Process"	Parameter	Display "Set" <i>[ex works]</i>	
<i>S h</i>	Switch-point interval { 46H, 4H, r/w }	<i>OFF</i> ; 0.1 to 80.0 <i>OFF</i> ; 0.01 to 8.00 <i>OFF</i> ; 0.001 to 0.800	[OFF] 1) 2)
This parameter raises the set-point (switch-point) for the cooling output by the displayed value. It can help to reduce the switching frequency between the heating and cooling outputs, if this is too high. Simultaneous activation of the heat and cool outputs is not possible.			
<i>2 P</i>	OUT 2 Xp cool, P-range { 50H, 5H, r/w }	<i>OFF</i> ; 0.1 to 100.0 %	[6.0]
If Xp = OFF, the next parameter to follow is <i>2 S d</i> (control sensitivity for OUT 2).			
<i>2 d</i>	OUT 2 Tv, Rate { 51H, 5H, r/w }	<i>OFF</i> ; 1 to 200 s	[30]
<i>2 J</i>	OUT 2 Tn, Reset { 52H, 5H, r/w }	<i>OFF</i> ; 1 to 1000 s	[150]
<i>2 C</i>	OUT 2 cycle time { 53H, 5H, r/w }	0.5 to 240.0 s	[15.0]
<i>2 S d</i>	OUT 2 control sensitivity Sd { 57H, 5H, r/w }	<i>OFF</i> ; 0.1 to 80.0 <i>OFF</i> ; 0.01 to 8.00 <i>OFF</i> ; 0.001 to 0.800	[0.1] 1) 2)
Adjustment of the control sensitivity, output OUT 2 (only if Xp = 0, no control action).			

- 1) Valid for ranges with a mantissa of one digit
2) Valid for ranges with a mantissa of two digits

Parameter level

The following parameters apply only to the configuration of 3-point step controllers

Display
"Process"

Parameter

Display "Set"
[ex works]

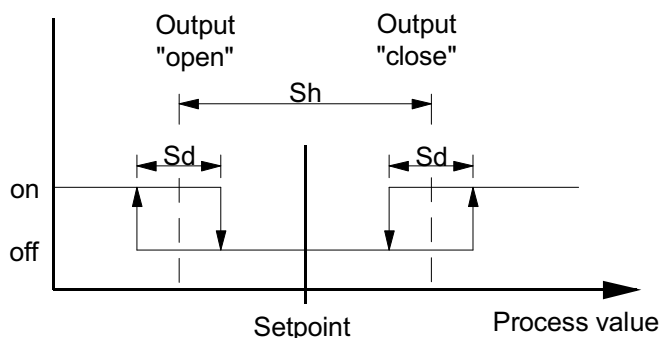

3-point step controllers use PI control action in combination with motor actuators. It is important, that S_h should be several times larger than S_d . Switching frequency is dependant on the pre-selected feedback values.

P	X_p , proportional range { 40H, 4H, r/w }	OFF; 0.1 to 200.0 %	[10.0]
t_s	Motor actuating time { 41H, 4H, r/w }	5 to 800 s	[40]
t_n	Reset time { 42H, 4H, r/w }	0.5 to 80.0 min	[3.0]
S_d	Control sensitivity { 47H, 4H, r/w }	OFF; 0.1 to 80.0 OFF; 0.01 to 8.00 OFF; 0.001 to 0.800	[0.1] 1) 2)
S_h	Switch-point interval { 46H, 4H, r/w }	OFF; 0.1 to 80.0 OFF; 0.01 to 8.00 OFF; 0.001 to 0.800	[0.1] 1) 2)

1) Valid for ranges with a mantissa of one digit

2) Valid for ranges with a mantissa of two digits

Parameter level

The following parameter applies to all controllers

Display "Process"	Parameter	Display "Set" [ex works]	
<i>OPt</i>	Autotune { 88H, 8H, r/w }	<i>[OFF]</i>	Autotuning not active.
		<i>on</i>	single autotune cycle, upon command.
		<i>Auto</i>	automatic triggering of the autotune every time the controller is switched on, if the momentary difference between the set-point and the process value is larger than 7 % of the total range.

The tuning algorithm determines the characteristic values within the controlled process, and calculates the valid feedback parameters (X_p , T_n , T_n) and the cycle time ($C = 0.3 \times T_v$) of a PD/I controller for a wide section of the range.

If the controller is used as a heat-cool controller, the determined parameters for heating are also adopted for cooling. Here though the value of X_p -range for cooling is doubled.

Autotuning activates during start-up shortly before the set-point is reached. The set-point must amount to at least 5 % of the total range. If activated after the set-point has already been reached, the temperature will first drop by approximately 5 % of the total range, in order to detect the exact amplification of the process. The tuning algorithm can be activated at any time by selecting the option *OPt = on* and pressing E. An adjust of output ratio limit is not considered.

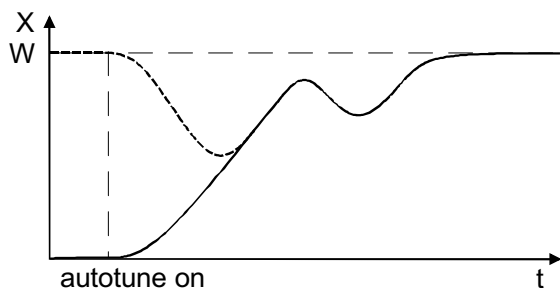

The optimization is time limited to 2 hours. If no usable control parameter are found, the optimization is stopped.

Under the following circumstances an auto-tuning error (*Err ?*) will be displayed:

- if soft-start is active
- if the controller is in manual operation or
- if a sensor break occurs.

Parameter level

Display "Process"	Parameter	Display "Set" <i>[ex works]</i>	
<i>0 F 5 t</i>	process value offset { 18H, 1H, r/w }	<i>OFF</i> ; -999 to 1000 <i>OFF</i> ; -99.9 to 100.0 <i>OFF</i> ; -9.99 to 10.00	<i>[OFF]</i> 1) 2)

This parameter serves to correct the input signal, e.g. for:

- the correction of a gradient between the measuring point and the sensor tip;
- line resistance balancing of 2-line Pt100 (RTD) sensors;
- correction of the control deviation when using P or PD action.

If for example the offset value is set to +5 °C, then the real temperature measured by the sensor (when the process is balanced) is 5 °C less than the set-point and the displayed process values.

1) Valid for ranges with a mantissa of one digit
2) Valid for ranges with a mantissa of two digits

Operating level

Display "Process"	Parameter	Display "Set" <i>[ex works]</i>	
Process value	Set-point 1 { 21H, 2H, r/w }	<i>OFF, SPLo to SPHi</i> , 4)	<i>[0]</i>
<p>Basic operating position If set-point 1 is set to "<i>OFF</i>", the controller switches to stand-by. The set display then shows "<i>OFF</i>". All main outputs are switched off, and the alarms are deactivated. All parameters can be displayed and altered during stand-by.</p> <p>Attention! Altering between control operation and manual operation is available by simultaneously pressing the + and - keys for a period of approximate two seconds. This adjustment is not stored with powerfail protection.</p>			

Only applicable to 3-point step controller configuration

<i>Hand</i>	Manual operation { 8CH, 8H, r/w }	<i>OFF, On</i>	<i>[OFF]</i>
<p><i>OFF</i>: Normal control operation of the unit.</p> <p><i>On</i>: The unit now works only as an actuator. The first parameter shown in the process display of the operating level is the momentarily valid process value. The word "<i>Hand</i>" appears in the set display (instead of the set-point). The outputs can now be manually activated by pressing either the + key (for OUT 1) or the - key (for OUT 2).</p> <p>The next parameter to appear is "<i>SP 1</i>", the set-point. This set-point has no influence while the controller is being operated manually, although it can be adjusted for later application.</p>			

<i>SP 2</i>	Set-point 2 { 22H, 2H, r/w }	<i>OFF; SPLo to SPHi</i> , 4)	<i>[OFF]</i>
<p>The second set-point is active when the external contact S1 is closed. The corresponding LED on the front panel lights up, and the second set-point is shown in the display. Please note, that the value of the second set-point cannot be changed in the basic operating position of the level. In order to change the value the parameter <i>SP 2</i> has to be selected.</p>			

4) SPLo = lower set-point limit, SPHi = upper set-point limit

Operating level

Display
"Process"

Parameter

Display "Set"
[ex works]

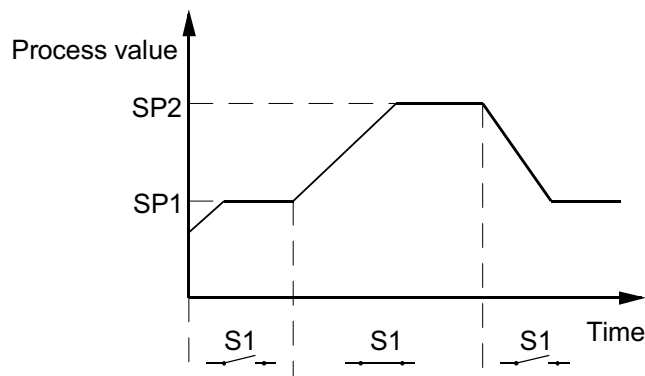

A programmed ramp is always activated when the set-point is altered or when the main supply is switched on.

The ramp constructs itself out of the momentary process value and the preselected set-point. If the ramp is active the corresponding LED lights up on the faceplate.

The ramp can be activated for both set-point 1 and set-point 2.

By programming the second set-point accordingly a set-point profile can be obtained (please see example above).

If a set-point ramp has been programmed, the soft start has priority, and the ramp will only become active after the soft start has been completed.

SP 2

Rising ramp
{ 2FH, 2H, r/w }

OFF; 0.1 to 100.0 units/min **[OFF]**
OFF; 0.01 to 10.00 units/min 1)
OFF; 0.001 to 1.000 units/min 2)

SP 4

Falling ramp
{ 2DH, 2H, r/w }

OFF; 0.1 to 100.0 units/min **[OFF]**
OFF; 0.01 to 10.00 units/min 1)
OFF; 0.001 to 1.000 units/min 2)

AL 1

Alarm 1
{ 38H, 3H, r/w }

Signal contact
OFF; -999 to 1000 **[OFF]**
OFF; -99.9 to 100.0 1)
OFF; -9.99 to 10.00 2)

Limit comparator
OFF; 1 to 1000
OFF; 0.1 to 100.0 1)
OFF; 0.01 to 10.00 2)

Limit contact
OFF; bottom end to top end range

The range of adjustment is dependent on the sensor and the alarm configuration. Both have to be set in the configuration level.

AL 2

Alarm 2
{ 39H, 3H, r/w }

for adjustments see Alarm 1

Alarm 2 is only available if the controller is programmed as a 2-point or continuous controller in the configuration level.

1) Valid for ranges with a mantissa of one digit

2) Valid for ranges with a mantissa of two digits

Hints for using the serial interface

The following parameters apply only to controllers equipped with a serial interface.

Status word 1 reports errors or alarm states ascertained by the controller.
This is a read-only operation.

Status word 1 { 70H, 7H, r }	bit 0 = 1:	System error
	bit 1 = 1:	Sensor error
	bit 2 = 0:	No function
	bit 3 = 1:	Reset control A reset was triggered during operation. The controller automatically resets bit 3 to 0 once status word 1 has been read by the computer.
	bit 4 = 0:	No function
	bit 5 = 1:	Alarm 1 triggered
	bit 6 = 1:	Alarm 2 triggered
	bit 7 = 1:	Setpoint ramp active

Status word 2 gives an overview of the operating state of the controllers. The computer can specify different operating states for the controller. If status word 2 is manipulated by the computer, bit 0 must always be set to '1' (remote controller operation). The controller remains then in remote operation.

Exception: controller ON/OFF can also be edited in local operation.

If the controller is switched back to local operation by the computer, bit 0 of the status word 2 may only be edited.

Status word 2 { 78H, 7H, r/w }	bit 0 = 0:	Controller operation remote or local
	1:	Controller operation remote
	bit 1 = 0:	Automatic mode (controller mode)
	1:	Manual mode (actuator mode)
	bit 2 = 0:	Autotune off
	1:	Autotune on
	bit 3 = 0:	Controller switched off
	1:	Controller switched on
bit 4 = 0:	No function	
bit 5 = 1:	Setpoint 1 valid	
bit 6 = 1:	Setpoint 2 valid	
bit 7 = 1:	No function	

Attention!

Status word 2 cannot be stored with powerfail protection. An eventual 'power off' can be checked via bit 3 (status word 1). Afterwards status 2 must be set again.

The selection of the valid setpoint via interface is only done in remote operation. In case of local operation the selection is controlled via the external contact S1.

Status word 2 is available for reasons of compatibility with older devices.

We, however, recommend the application of appropriate individual parameters 8B H, 88 H, 21 H and 22 H.

Process value output: (as casting-device)

Corresponding to the process value the controller generates a scalable signal (0/4...20mA; 0...10V) which is available on the terminals 21/22

Technical data:

- **Process value output:**

Output type (current or voltage) is determined automatically, dependent on load.

DC 0/4 to 20 mA (load of ≤ 500 Ohm)

DC 0/2 to 10 V (load of ≥ 1 k-Ohm)

Linearity: $< 1,5$ %

Delay time: app. 2 s

- The second alarm is unapplicable. Parameter „*CoR2*“ and „*RiL2*“ are omitted.
- The configuration of OUT 1 and OUT 2 in the configuration level is modified.
Note: now OUT 1 and OUT 2 cannot be used as a continuous output .

<i>Out</i>	Configuration of outputs		OUT1:	OUT2:
		<i>ir2r</i>	Relay	Relay
		<i>ib2r</i>	bistable	Relay
		<i>ir2b</i>	Relay	bistable
		<i>ib2b</i>	bistable	bistable

- Additional parameters in the configuration level:

<i>PrcL</i>	Configuration of process-outputs	<i>0-20</i>	<i>0...20mA / 0...10V</i>
		<i>4-20</i>	<i>4...20mA / 2...10V</i>

PrcH Output range; top end *PrcL*...top range end [ex works: 400]

PrcL Output range; bottom end bottom range end...*PrcH* [ex works: 0]

The difference between the bottom end and top end must amount to a minimum of 100 units. By adjustment of one of the above parameters, there is automatic correction, if necessary.

Error messages

Errors during setting

Display	Cause	Possible remedy
<i>S P L o</i>	Lower set-point limit has been reached	Reduce limit, if necessary
<i>S P H i</i>	Upper set-point limit has been reached	Increase limit, if necessary
<i>r L o</i>	Bottom range end has been reached (standard signal input)	Reduce limit, if necessary
<i>r H i</i>	Top range end has been reached (standard signal input)	Increase limit, if necessary
<i>L O C</i>	Parameter has been locked	Unlock, if necessary

Errors during control operation

Display	Cause	Possible remedy
<i>H R n d</i>	The controller has been programmed for manual operation. The unit has switched over to automatic owing to sensor defect.	Check sensor and cable
<i>E r r 1</i>	Bottom range end has been exceeded, sensor defect	Check sensor and cable
<i>E r r 2</i>	Top range end has been exceeded, sensor defect	Check sensor and cable
<i>E r r 7</i>	Auto tuning error	Extinguish error signal by pressing E. check auto tune conditions, restart.
<i>E r r 8</i>	Data error	Extinguish error signal by pressing E, and check all parameters. If the error signal continues please send the controller back to the manufacturer for examination.

Accessories for 5310 / 5320 (to be ordered separately)

Adapter for case size 96 mm x 96 mm, 1/4 DIN

Panel cut-out: 92 mm x 92 mm
Controller size: 48 mm x 96 mm

Type: A2/96x96
Order-No.: 39 4053 0000 1000

Parameter list

Operating level		Parameter level		Configuration level	
<i>SP 1</i>		<i>y</i>	not adjustable	<i>Conf</i>	
<i>SP 2</i>		<i>1 Ly</i>		<i>COUt</i>	
<i>SP2-</i>		<i>2 Ly</i>		<i>SEn</i>	
<i>SP4-</i>		<i>1 P</i>		<i>CONP</i>	
<i>AL 1</i>		<i>1 d</i>		<i>r dP</i>	
<i>AL 2</i>		<i>1 J</i>		<i>r H_i</i>	
<i>HRnd</i>		<i>1 C</i>		<i>r Lo</i>	
		<i>1 Sd</i>		<i>SPH_i</i>	
		<i>Sh</i>		<i>SPLo</i>	
		<i>2 P</i>		<i>CoR 1</i>	
		<i>2 d</i>		<i>CoR 2</i>	
		<i>2 J</i>		<i>So Y</i>	
		<i>2 C</i>		<i>SoSP</i>	
		<i>2 Sd</i>		<i>So_t</i>	
		<i>P</i>		<i>HRnd</i>	
		<i>tS</i>		<i>CoSb</i>	
		<i>t_n</i>		<i>LOC</i>	
		<i>Sd</i>		<i>Rdr</i>	
		<i>Sh</i>		<i>bRud</i>	
		<i>OPT</i>		<i>For</i>	
		<i>OFSt</i>		<i>S3 10</i>	not adjustable