

Bargraph indicator BA 9624A

Features

- Multipurpose input 0/4 ... 20 mA and 0 ... 10 V DC
- 2 programmable limit contacts, high or low alarm selectable.
- 20 segments bargraph with 3-digit LED Display, free adjustable in the range -99 ... 999 Digit. Display and bargraph can be independently scaled
- Programmable indicating time 0.1 ... 10 s
- Front panel buttons
- Full 2-port isolation
- Supply voltage 230 V AC, or 24 V DC
- Front protection IP54 (IP65 optional)



Technical data

Power supply

Supply voltage	: 230 V AC, $\pm 10\%$, 50/60 Hz; 24 V DC $\pm 10\%$
Power consumption	: approx. 5 VA
Operating temperature	: 0 ... 60 °C (32 ... 140°F)
Temperature coefficient	: 50 ppm/K
CE-Konformität	: EN 61010, EN 50081-1, EN50082-2

Inputs

Current input	: 0/4 ... 20 mA, Ri 100 Ω
Voltage input	: 0 ... 10 V DC, Ri 83k Ω

Indicating

Bargraph	: 20 segments LED red or green
Digital display	: LED, 7 mm red; -99 ... 999 digit
Indicating time (Average)	: programmable in range 0.1 ... 10sek
Overrange	: flashing " - - - "
Accuracy	: $\pm 0.2\%$; 1 segment (analogue); ± 1 digit (digital display)

Output

2 relay SPDT limit contact	: 230 V AC/2 A or 120 V DC/0.5 A
----------------------------	----------------------------------

Case

Type	: plug-in case, Polycarbonate / front panel ABS
Installation	: 2 mounting clips, up to 50 mm wall thickness
Weight	: approx. 0.29 kg
Protection	: Front IP40, terminals IP00
Connections	: Screw terminals, max. 2.5mm ²

Dimension

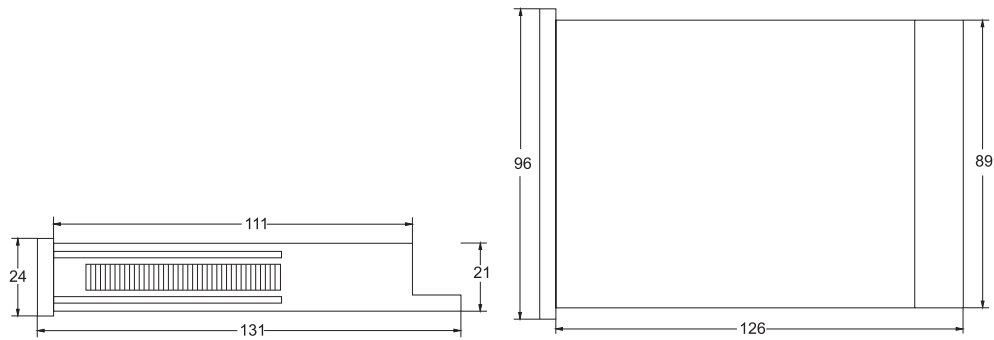

Connection diagram

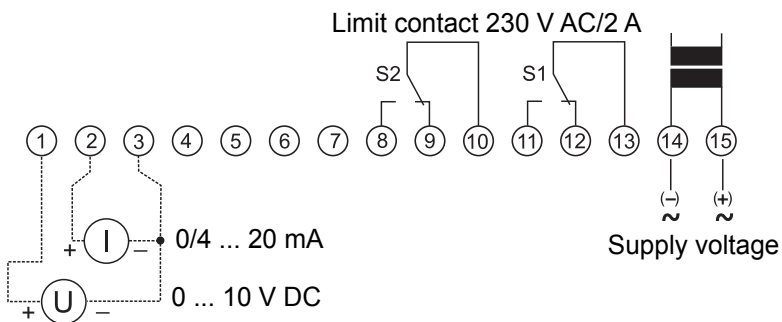

Front controls

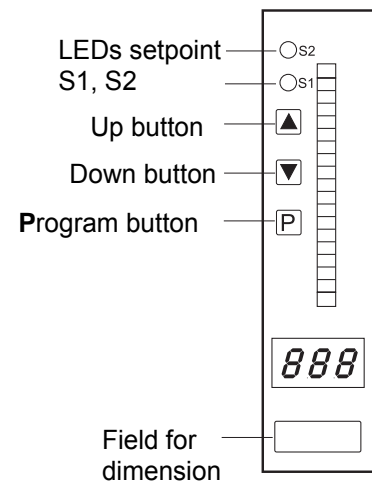

Programming

1. Device connection as connection diagram.
2. Switch on supply voltage. The device starts with the LED-test and change to the operational mode.
3. Maximum signal value at the input.
4. Press program-button **P**. Program number 1 is indicated.
5. Press the **P** and **▲** - button at the same time to change the program number.
6. Pressing the **▲**- or **▼**- button shows the value which is stated at the current program number.
7. The value could be changed with the **▲**- or **▼** - button.
8. Only at program 1 or 2 the value of the input must be saved by pressing the **P** - and **▼**- button at the same time. The saving status is displayed with "- - -".
9. The device has a 7 second program timeout. If no buttons are pressed for 7 seconds at any step of the programming sequence, the device will leave the program mode and returns to the working level. The changes in the preceding step will be saved.

Additional functions at the operational mode to the saved MIN / MAX values.

Pressing **▼**- and **▲**- button together clear and actualises the MIN / MAX-memory.

Pressing the **▲**-button, displays the MAX -memory.

Pressing the **▼**-button, displays the MIN -memory.

After the device has been powered up, the 3 digits and the bargraph light up for approx. 3 seconds and then returns to the the input signal.

If there are any errors during the start sequence or in the operational mode, the display shows *H L P*. Now it's nessecary to reset the system. Press the **P** -Button and power up the device. The device starts with the LED-test until releasing the **P** -Button. The factory setting will remain. The program procedure must start again.

Programming

Program code input indicator

PN	Function	Display	Factory settings
1	End value (max. input signal; store with buttons P and ▼)	-99 ... 999	200
2	Start value (max. input signal; store with buttons P and ▼)	-99 ... 999	0
3	Decimal point	<i>0.0.0</i>	non
4	Display refreshing	0,1 ... 10,0s	0.5s
9	End value bargraph		200
10	Start value bargraph		0
30	Characteristic curve linearisation. 1 activates PN31-38. The curve must have a increasing character. The points will be calculated between PN1 and PN2 (max. input signal; store with buttons P and ▼)	0=deactive 1=active	0
31	Lin. point 1	-99 ... 999	22
32	Lin. point 2	-99 ... 999	44
33	Lin. point 3	-99 ... 999	66
34	Lin. point 4	-99 ... 999	88
35	Lin. point 5	-99 ... 999	111
36	Lin. point 6	-99 ... 999	133
37	Lin. point 7	-99 ... 999	155
38	Lin. point 8	-99 ... 999	177

Program code limit contacts

PN S1	PN S2	Display	Factory settings
61	66	Setpoint, -99...999	50/150
62	67	Hysteresis 0...999	1
63	68	0=Min; 1=Max	

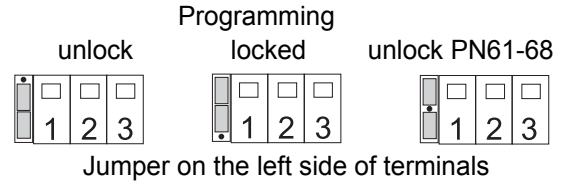

Description:

Press the **P** - Button. Step1 is always PN1. The display shows the Program number. After 3s the display toggles between PN and previous setting. Press the **▼**- or **▲** -Button to reach the edit mode. The display value can be increased or decreased by pressing and releasing the **▲**- or **▼**- Button. Only at PN1 and PN2 the values must be stored by pressing the **P** - and **▼**- Buttons at the same time. 3 centre lines " - - - " indicate that the actual value is stored.

Press the **P** - and **▲**-Button at the same time to go onto the next programming step. It's the same procedure in every Step as described before. If no Buttons are pressed for 7 seconds at any stage of the programming mode, the device will leave the program mode and return to the operational mode. It's possible to leave the programming mode by pressing the **P** - Button at any time.

Continue page 4

Programming

1. Power on.
Max. input signal.
2. Press **P** → P1
With ▲- or ▼- button, increase or decrease the end value. Store with **P** and ▼-button.
3. Press **P** - and ▲- button to change to PN 2. Min. input signal. With ▲- or ▼- button increase or decrease the start value. Store with **P** - and ▼- button.
4. Press **P** - and ▲- button to change to PN 3. Press ▲- or ▼- button, now set the decimal point with the ▲- button.
5. Press **P** - and ▲-button to change to PN 4. Press ▲- or ▼- button for the indicating time value.
6. Press **P** - and ▲- button to change to PN9. Press ▲- or ▼- button to adjust the end value of the bargraph.
7. Press **P** - and ▲- button to change to PN10. Press ▲- or ▼- button to adjust the start value of the bargraph.
8. Press **P** - and ▲-button to change to PN30. ▲- or ▼-button activates the linearisation.
9. Press **P** - and ▲-button to change to PN31. With ▲- or ▼- button adjust set point 1. To delete, set value to Zero. Store with **P** - and ▼-button. The following points N32-N38 are identical with N31.
10. Press **P** - and ▲-button to change to PN61. With ▲- or ▼- button adjust set point S1.
11. Press **P** - and ▲- button to change to PN62. With ▲- or ▼- button set the hysteresis (Dead Band) for S1.
12. Press **P** - and ▲-button to change to PN63. Press ▲- or ▼- button and select 0 for Low or 1 for High contact set point 1.
13. Press **P** - and ▲- button to change to PN66. With ▲- or ▼- button adjust set point S2.
14. Press **P** - and ▲- button to change to PN67. With ▲- or ▼- button set the hysteresis (Dead Band) for S2.
15. Press **P** - and ▲- button to change to PN68. Press ▲- or ▼- button and select 0 for Low or 1 for High contact set point 2.

The bargraph programming mode is now finished.

Ordering code

BA9624A - 1. - 2. - 3. - 4. - 5.

1. Mounting direction

- 1 vertical
- 2 horizontal

2. Display color

- 1 red
- 2 green

3. Supply voltage

- 0 230 V AC ±10 %
- 5 24 V DC ±10 %

4. Measuring range, scale 0-100 %

- 10 Input 0/4 ... 20 mA and 0 ... 10V DC

5. Protection (Front)

- 1 IP54
- 2 IP65