

DMS-Bridge Panelmeter DMS 9648

Weight - force - pressure - torque with DMS-bridges

Features

- LED-Display 14.2 mm red
- Display range $\pm 9999(0)$ Digit
- Indicating range and decimal point free programmable
- Teach-in-function
- Tare-function
- Integrated bridge supply 5/10 V DC
- 1- or 2 way action programmable
- Max. 8 Parameter sets programmable
- Max. 4 outputs SPDT relay or transistor
- Isolated analog output
0/4 ... 20 mA or 0/2 ... 10 V DC
- Front protection IP65



General

The DMS-Bridge Panelmeter DMS9648 is designed for measuring forces, pressure and torques with DMS-bridges. The device offers a programmable bridge-supply 5/10 V DC; max. 50 mA output current. Measuring errors due to line resistance can be compensated by using a sense line. Indicating range and decimal point are free programmable in range ± 9999 digit (standard) and ± 99990 (dummy zero selected).

Short information

Programming	Parameters are programmed via front-side membrane keypad.
Alarm outputs	Switching performance min. or max., hysteresis, on-delay time and off-delay time are programmable in range from 1 s up to 9 h.
Digital filter	With activated digital filter the last 16 measured values will be averaged continuously. The result is shown in the display.
Analog output	An isolated analog output signal 0 ... 20 mA/0 ... 10 V DC or 4 ... 20 mA/2 ... 10 V DC can be generated proportional to the input signal. Output changed automatically from current signal to voltage signal, depending on burden.
Teach-in function	The sensitivity and tare of the DMS-bridge can be determined by two known weights/forces.

Technical data

Power supply

Supply voltage	: 230 V AC $\pm 10\%$; 115 V AC $\pm 10\%$, 24 V AC $\pm 10\%$ or 24 V DC $\pm 15\%$
Power consumption	: max. 3.5 VA, with analog output 5 VA
Operating temperature	: -10 ... +55 °C, 14 ... 131 °F
Rated voltage	: 250 V _{rms} acc. VDE 0110 between input/output/supply voltage Degree of pollution 2, over-voltage category III
Test voltage	: 4 kV=, between input/output/supply voltage
CE - conformity	: EN55022, EN60555, IEC61000-4-3/4/5/11/13

Input

Bridge supply	: 5 V DC or 10 V DC ; programmable; max. 50 mA
Bridge resistance	: at 5 V min. 100 Ω ; at 10 V min. 200 Ω
Bridge sensitivity	: 0.900 ... 6.600 mV/V programmable
Sense connection	: Line resistance of max. 10 Ω can be compensated
Accuracy	: < 0.1 % ± 2 Digit
Temperature coefficient	: 0.005 %/K

Display

Display	: LED red, 14.2 mm
Display range	: $\pm 9999(0)$ digit , leading zero suppression.
Parameter display	: LED 2-digit red, 7 mm (parameter - and output indicator)

Output

Relay	: SPDT < 250 V AC < 250 VA < 2 A, < 300 V DC < 50 W < 2 A
Transistor	: max. 35 V AC/DC, 100 mA, short circuit protected
Analog output	: 0/4 ... 20 mA burden $\leq 500 \Omega$; 0/2 ... 10 V burden $> 500 \Omega$, isolated Automatic output changing (burden dependent)
-Accuracy	: 0.1 %; TK 0.01 %/K

Panel case

Dimensions	: DIN 96x48 mm, material PA6-GF; UL94V-0
Weight	: max. 390 g
Electrical connection	: Clamp terminals, 2 mm ² single wire, 1,5 mm ² flexible wire, AWG14
Protection	: Front IP65, terminals IP20, fingersafe acc. to German BGV A3

Dimensions

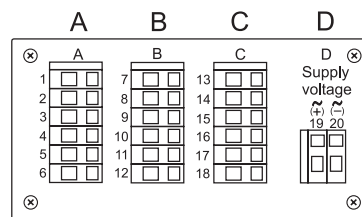
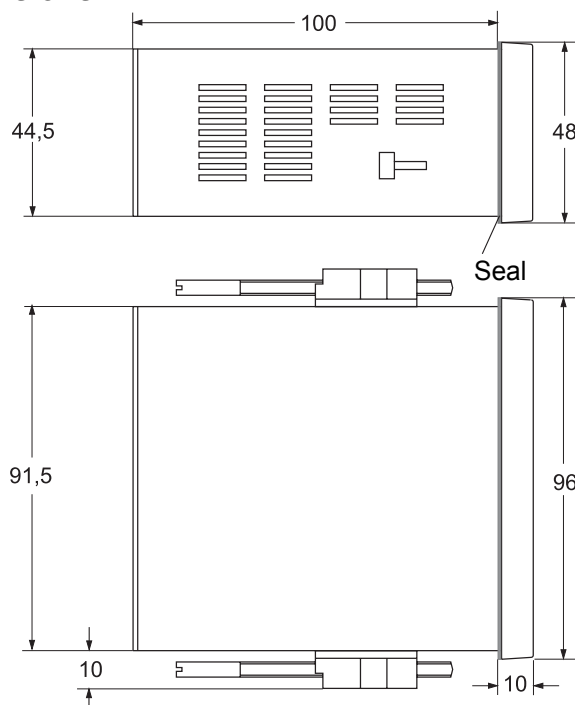

Terminal strip position

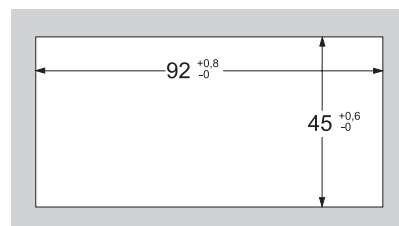

Panel cut-out acc. to
DIN 43700-96x48

Connection diagrams

Terminal strip A

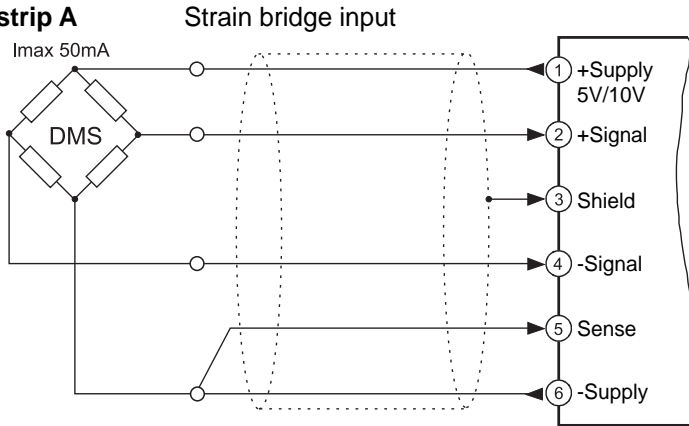

The sense input is used to compensate line resistance from DMS-strain gauge to panelmeter DMS9648. For distances > 5 m the use of sense input is recommended.

Terminal strip B (varies with version)

2 alarm outputs

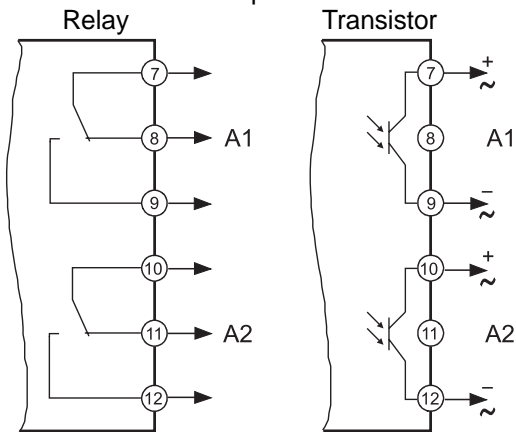

Terminal strip C (varies with version)

2 alarm outputs

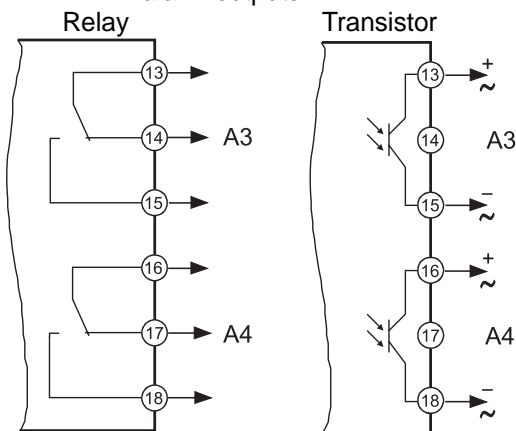

Analog output AO

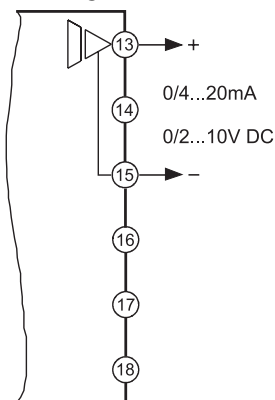

Terminal strip D supply voltage (varies with version)

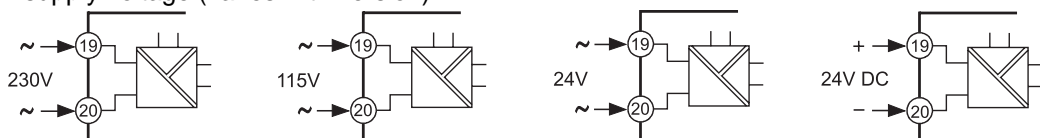

Controls and indicators

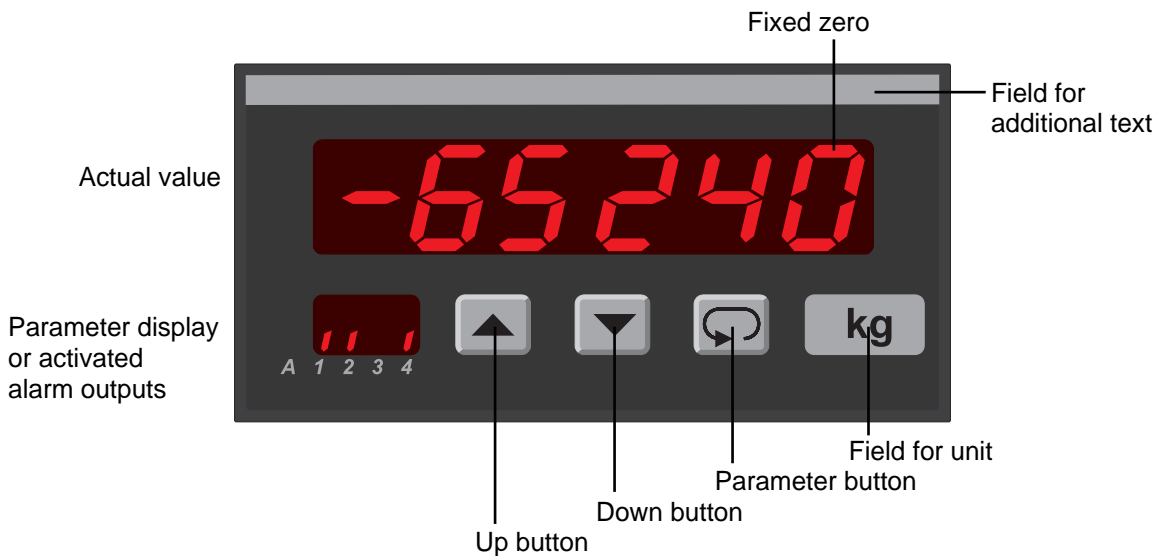

Description

Operating of the device is arranged in 2 levels. The requested parameter can be called by button . For selections within a parameter or for entering data, use buttons and . Parameters are stored zero-voltage safe in the EEPROM.

After power-on, the device initializes itself. The display shows the message *Unit*.

After the initializing procedure the device is located in the **Working level**. Set points of the alarm outputs can be preselected if they are available.

Pressing the button for more than 2 seconds, activates the **Configuration level**. Now all the parameters which defines the function of the panelmeter can be programmed. E.g. the switching performance of the alarm outputs and the analog output.

After finishing the configuration or when no button was pushed for more than 2 minutes, the program returns to the working level. Leaving the configuration level is possible at any time by pressing the button for more than 2 seconds.

Parameter display as status indicator for the alarm outputs A1-A4.

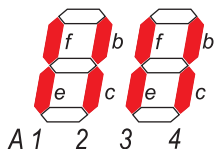

Segments f (A1 / A3) and/or b (A2 / A4) are flashing with 2 Hz, when delay time is active.

Segments e (A1 / A3) or c (A2 / A4) are output indicators.

Start-up note:

The device has to be configured, before it can be used

⇒ see page 6











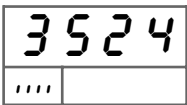



Notes to representation

Parameter is only displayed if configured

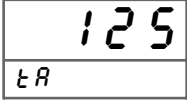

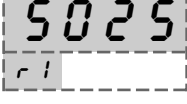

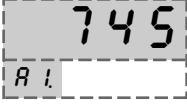





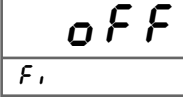



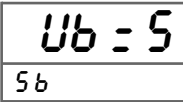



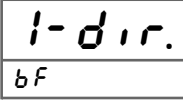



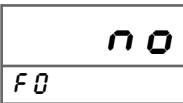









Parameter is only displayed if included (see order code)

Note: All parameters can be called if they are not blocked by other programmed parameters and if they are available. Factory settings are shown in the **display graphic**.

Working level

Button	Display	Description
		Process value Output indication. (only if installed and activated)
		Display brightness Permanent setting in the working level possible, in 9 steps with buttons ▲ and ▼.
		Max. peak reading. Reset with buttons ▲ or ▼, and at every power off.
		Min. peak reading. Reset with buttons ▲ or ▼, and at every power off.
		Tare-function; sensor offset or measuring error e.g. an empty container. Pressing button ▲ for more than 3 s, will reset the display to ZERO.
		Selection of the parameter sets r1 ... r8. Selection with buttons ▲ or ▼. Each parameter set includes the measuring range and the output setpoints.
		Setpoint output A1. Setting possible from 0... ± measuring end value with buttons ▲ and ▼. Note: At model 2 only the selected parameter set will be affected.
		Set points for alarm outputs A2 - A4 have to be configured in the same way.

Configuration level

Button	Display	Description (Display graphic shows factory settings)
 Press 2s	1 	Digital filter. <i>oFF</i> , <i>oN</i> ; continuously averaging of the last 16 measured values. Selection with buttons  and  .
 	2 	Bridge supply <i>Ub = 5</i> → 5 V DC <i>Ub = 10</i> → 10 V DC Selection with buttons  and  .
 	3 	Action of direction <i>1-dir.</i> 0 ... measuring end value <i>2-dir.</i> 0 ... ± measuring end value. Selection with buttons  and  . ! In case of modification a new configuration of the alarm outputs is necessary.
 	4 	Fixed zero 0, e.g. 3590(0). <i>no</i> ; <i>YES</i> Selection with buttons  and  .
 	5 	Decimal point position if <i>FD</i> = <i>no</i> : 0. 0 .00 .000 if <i>FD</i> = <i>YES</i> : 0. 00 .000 .0000 Selection with buttons  and  . ! In case of modification a new configuration of the alarm outputs is necessary.
 	Model 1 6 	Model 1: only 1 parameter set Measuring end value, nominal load of the DMS-bridge Setting possible from 0 ... 9999 digit with buttons  and  . ! In case of modification a new configuration of the alarm outputs is necessary.
 	Model 2 7 	Model 2: 8 parameter sets Measuring end value, nominal load at leverage ratio program <i>r!</i> Setting possible from 0 ... 9999 digit with buttons  and  . ! In case of modification a new configuration of the alarm outputs is necessary.
 	14 	

continue
page 7

Button	Display	Description (Display graphic shows factory settings)
↓	<div style="border: 1px solid black; padding: 5px; display: inline-block;"> <div style="text-align: right; margin-bottom: 5px;">15</div> <div style="text-align: center; font-size: 24px; margin-bottom: 5px;">n 0</div> <div style="font-size: 18px; margin-bottom: 5px;">t E</div> </div>	<p>Start teach-in</p> <p>n 0 continue with parameter 18, b 5 (bridge sensitivity)</p> <p>y E 5 continue with parameter 16, t 1</p> <p>Selection with buttons ▲ and ▼.</p>
↺		
↓	<div style="border: 1px solid black; padding: 5px; display: inline-block;"> <div style="text-align: right; margin-bottom: 5px;">16</div> <div style="text-align: center; font-size: 24px; margin-bottom: 5px;">0.</div> <div style="font-size: 18px; margin-bottom: 5px;">t 1</div> </div>	<p>Teach-in 1. calibration point</p> <p>Set the actual loaded weight within the measuring range with buttons ▲ and ▼.</p> <p>This parameter will not be left automatically after 2 minutes.</p>
↺		
↓	<div style="border: 1px solid black; padding: 5px; display: inline-block;"> <div style="text-align: right; margin-bottom: 5px;">17</div> <div style="text-align: center; font-size: 24px; margin-bottom: 5px;">0.</div> <div style="font-size: 18px; margin-bottom: 5px;">t 2</div> </div>	<p>Teach-in 2. calibration point</p> <p>The difference to the 1. calibration point has to be at least 10% of the programmed measuring range. Setting possible with buttons ▲ and ▼.</p> <p>This parameter will not be left automatically after 2 minutes.</p> <p>Pressing button ↺, the bridge sensitivity and tare-value are calculated automatically.</p>
↺		
↓	<div style="border: 1px solid black; padding: 5px; display: inline-block;"> <div style="text-align: right; margin-bottom: 5px;">18</div> <div style="text-align: center; font-size: 24px; margin-bottom: 5px;">2.000</div> <div style="font-size: 18px; margin-bottom: 5px;">b 5</div> </div>	<p>Bridge-sensitivity [mV/V]</p> <p>Setting possible from 0.900 ... 6.600 mV/V (in accordance to the bridge supply) with buttons ▲ and ▼.</p>
↺		
↓	<div style="border: 1px solid black; padding: 5px; display: inline-block;"> <div style="text-align: right; margin-bottom: 5px;">19</div> <div style="text-align: center; font-size: 24px; margin-bottom: 5px;">o f f</div> <div style="font-size: 18px; margin-bottom: 5px;">R 1</div> </div>	<p>Switching performance output A1.</p> <p>Function o f f ; o n L (min); or o n U (max)</p> <p>Selection with buttons ▲ and ▼.</p> <p>In case of modifications a new configuration of the alarm output is necessary.</p> <p>Model 2: all parameter sets are affected and have to be reconfigured.</p>
↺		
↓	<div style="border: 1px dashed black; padding: 5px; display: inline-block;"> <div style="text-align: right; margin-bottom: 5px;">20</div> <div style="text-align: center; font-size: 24px; margin-bottom: 5px;">0</div> <div style="font-size: 18px; margin-bottom: 5px;">R 1</div> </div>	<p>Setpoint output A1.</p> <p>Setting possible from 0 ... measuring end value or ± end value with buttons ▲ and ▼.</p> <p>Note: model 2 only for the selected parameter set.</p>
↺		
↓	<div style="border: 1px dashed black; padding: 5px; display: inline-block;"> <div style="text-align: right; margin-bottom: 5px;">21</div> <div style="text-align: center; font-size: 24px; margin-bottom: 5px;">10</div> <div style="font-size: 18px; margin-bottom: 5px;">H 1</div> </div>	<p>Hysteresis output A1.</p> <p>Setting possible from 1 ... 9999 (0) digit with buttons ▲ and ▼.</p> <p>Model 2: hysteresis is valid for all parameter sets.</p>
↺		
		<p>Note: Parameters for alarm output A2 ... A4 have to be configured in the same way.</p>

continue
page 8

Button	Display	Description (Display graphic shows factory settings)
↓ ↺	22 0.00.00 t 1	Switch-on delay time output A1. Setting possible from 0.00.00 ... 9.00.00 (h.mm.ss) with buttons ▲ and ▼.
↓ ↺	23 0.00.00 t 1	Switch-off delay time output A1. Setting possible from 0.00.00 ... 9.00.00 (h.mm.ss) with buttons ▲ and ▼.
		Note: Set points for alarm outputs A2 - A4 have to be configured in the same way.
		Option 08 only possible with model 2!
↓ ↺	24 0 - 20 R 0	Analog output 0 - 20 mA (0 - 10 V DC) 4 - 20 mA (2 - 10 V DC) The switch-over from current to voltage output is load dependent (≤ 500 Ω = current output, > 500 Ω = voltage output). Selection with buttons ▲ and ▼.
↓ ↺	25 0 R 5	Analog output Start value Setting possible in the measuring range with buttons ▲ and ▼.
↓ ↺	26 1000 R E	Analog output End value Setting possible in the measuring range with buttons ▲ and ▼. If the measuring end value will be changed afterwards, the analog output start value is set to 0/measuring end value. The analog output end value is set to the measuring and value. If R5 > RE the analog output works with a decreasing characteristic.
↓ ↺	27 00 L 0	Code for factory settings
↓ ↺	28 oFF L c	Parameter lockout oFF = no lock L onF. = configuration level locked R LL = all parameters locked Selection with buttons ▲ and ▼.
	3524	Return to the working level

Error codes

Display

Description

Display flashes If the measured signal is more than 3 % outside of the programmed range or/if the A/D- converter is out of range and the display flashes with 1 Hz.

A rectangular display box showing the text "Error 1." in a monospaced font.

EEPROM test. Reading this message, a parameter error was detected. By pressing the button  a copy of the factory settings will be reloaded to the EEPROM. The device will work with the factory settings. If this copy does not work, please ship the panelmeter for factory repair.

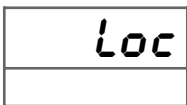
A rectangular display box showing the text "Loc" in a monospaced font.

Parameter lockout. See configuration page 8.

The following error messages are displayed, if wrong values are programmed at the teach-in function. The error message flashes for 3 s. After that, parameter 15 (ϵE) will be displayed.

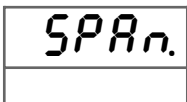
A rectangular display box showing the text "SPAn." in a monospaced font.

The programmed span is < 10 % of the measuring end value

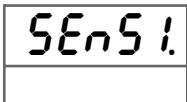
A rectangular display box showing the text "SEnS I." in a monospaced font.

The determined bridge sensitivity is out of range.

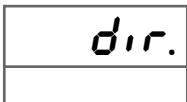
A rectangular display box showing the text "dir." in a monospaced font.

The programmed values and measured voltage are in the reverse direction.

More DMS-bridge devices

DMS-bridge converter DMS 1000

- 1- or 2-way action programmable
- Teach-in function
- Front side LCD-display with back lightning
- Programming via front keypad
- Tare-function (internal / external) and simulation mode
- Integrated bridge-supply 2,5 V/5 V/10 V max. 50 mA
- Accuracy <math><0.05\% \pm 2 \text{ digit}</math>
- Analog output 0/4...20 mA; 0...10 V DC
- Alarm output (relay SPDT)
- Wall and DIN-rail(TS35) mounting



DMS-bridge amplifier SBB 1616

- Bridge supply 2 ... 10 V
- max. 6 DMS-bridges $\geq 300 \Omega$ at 10 V
- Output current max. 200 mA (short circuit proof)
- Line compensation (Sense) up to max. voltage drop 1 V
- Case aluminium IP65



Precision load-cell series PK

- DMS-bridge, bridge resistance 350 Ω
- Output signal 2 mV/V
- Accuracy model 01 + 02 0.05 %
model 03 + 04 0.1 %
- Bridge supply max. 20 V DC, recommend 10V DC
- Connection cable 2m
- Protection IP65, model 01 IP40



Model 04

Model 01-03

0 ... 2 kg up to 0 ... 1 t

Load-cell series KR

- DMS-bridge, bridge resistance 350/700 Ω
- Output signal 2 mV/V
- Accuracy 0.2 %
- Bridge supply max. 20 V DC, recommend 10 V DC
- Connection cable 2 m
- Protection IP65



0 ... 50 kg up to 0 ... 30 t

Load-cell series KS

- DMS-bridge, bridge resistance 350/700 Ω
- Output signal 2 mV/V
- Accuracy 0.2 %
- Bridge supply max. 20 V DC, recommend 10 V DC
- Connection cable 2 m
- Protection IP65



0 ... 50 kg up to 0 ... 100 t

Shear-beam load-cell series BL

- DMS-bridge, bridge resistance 350 Ω
- Output signal 2 mV/V
- Accuracy 0.02 %
- Bridge supply max. 18 V DC,
- Connection cable 2 m
- Protection IP66



0 ... 500 kg up to 0 ... 20 t

Beam-type load-cell series SB

- DMS-bridge, bridge resistance 350 Ω
- Output signal 3 mV/V
- Accuracy 0.02 %
- Bridge supply max. 15 V DC,
- Connection cable 2 m
- Protection IP66

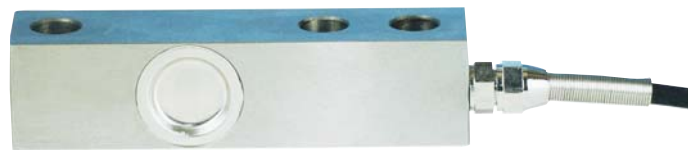

0 ... 500 kg up to 0 ... 10 t

Melt pressure transmitter series MDA

- for plastic- and food-industry applications
- DMS-bridge, bridge resistance 350 Ω
- Output signal 3.3 mV/V, 0...10 V DC or 4...20 mA
- Accuracy 0.5 % or 0.25 % (optional)
- Bridge supply 6 ... 12 V DC,
- Medium temperature 0 ... 400° C
- Process connection 1/2"-20UNF-2A, M14x1.5 or M18x1.5
- Electrical connection 6-pole plug
- Protection IP66



0 ... 35 bar up to 0 ... 2000 bar

Ordering code

DMS9648 - 1. - 2. - 3. - 4. - 5. - 6. - 7.

1. Terminal strip A

- 0 Input DMS-bridge 1 parameter set
integrated bridge supply 5/10 V DC max. 50 mA
- 1 Input DMS-bridge 8 parameter sets
integrated bridge supply 5/10 V DC max. 50 mA

2. Terminal strip B

- 00 not installed
- 2R 2 alarm outputs relay
- 2T 2 alarm outputs transistor

3. Terminal strip C

- 00 not installed
- 2R 2 alarm outputs relay
- 2T 2 alarm outputs transistor
- AO Analog output 0/4 ... 20 mA or 0/2 ... 10 V DC
isolated

4. Terminal strip D supply voltage

- 0 230 V AC ± 10 % 50-60 Hz
- 1 115 V AC ± 10 % 50-60 Hz
- 4 24 V AC ± 10 % 50-60 Hz
- 5 24 V DC ± 15 %

5. Option

- 00 without option
- 01 min- and max-peak-hold
- 07 display brightness programmable
- 08 analog output separately programmable in the measuring range
(only model 1, with 1 parameter set DMS9648- 1 - xx)

6. Unit (on the panel front)

- 7. **Additional text** (on the additional text field on the panelmeter,
maximum 3 x 90mm WxH)