

Digital Panelmeter DP 4848A

Voltage - current - resistance or RTD, Pt100 - Pt1000

Features

- Multipurpose input
0/4 ... 20 mA, 0/2 ... 10 V DC
and potentiometer
- Measuring input for RTD sensors
Pt100 -99.9 ... 99.9 / -100...600 °C switch selectable
Pt1000 -19.9 ... 99.9 °C
- Adjustable display range (standard signal device only)
-99 ... +999
(no extern signal source necessary !)
- Decimal point switch selectable
- Display LED red or green 14.2 mm
- 20-turn adjustable trimmer for initial value and span
- Supply voltage 10.8 ... 30 V DC and 17 ... 30 V AC
with isolation.
- Front protection IP54 (IP65 optional)
- Plug-in screw terminal



General information

Digital panelmeter DP4848A are designed for measurement applications in process technology and automation. The small cases are suitable for installation in control units and panel boards. The universal conception of the multipurpose input allows indication of all physical dimensions, which can be converted to 0/4...20mA or 0/2...10V DC. The display range can be adjusted without an external signal source. Other models of the DP4848A are useful for temperature measurement with Pt100 or Pt1000 sensors. The input-configuration is switch selectable from the side, without opening the case. Input and supply voltage are isolated.

Technical data

Power supply

Supply voltage	: 10.8 ... 30 V DC; 17 ... 30 V AC
Frequency	: 47 ... 63 Hz
Power consumption	: ca. 1.2VA
Working temperature	: -10 ... +60 °C (14 ... 140 °F)
Test voltage	: 500V DC input/supply voltage
CE-conformity	: EN55022, IEC61000-4-2/4/11

Measuring input

Voltage	: $R_i = 40 \text{ k}\Omega$
-overload	: max. 48 V
Current	: $R_i = 125 \Omega$
-overload	: max. 60 mA
Pt100 measur. current	: approx. 1 mA (no self heating)
Pt1000 measur. current	: approx. 0.2 mA (no self heating)
Accuracy	: < 0.05 % +/-1 Digit
Temperature coefficient	: < 50 ppm/K
Linearisation error	: < 0.1 %

Display

Conversion rate	: approx. 2/s
Range	: -199 ... +999 Digit only multipurpose device
	: -19,9 ... +99,9 °C/-100 ... +600 °C Pt100
	: -19,9 ... +99,9 °C Pt1000
Color	: 3 digit, red or green 14.2 mm
Decimal point	: switch selectable
Overflow indication	: display flashing with 2 Hz
Case	: slide-in unit according to DIN 43700 of Noryl GFN 2 SE 1
Weight	: 0.1 kg
Connection	: plug-in terminal, IP20 (BGV A3), max 1.5 mm ²
Protection front	: IP54 (IP65 optional)

Dimensions

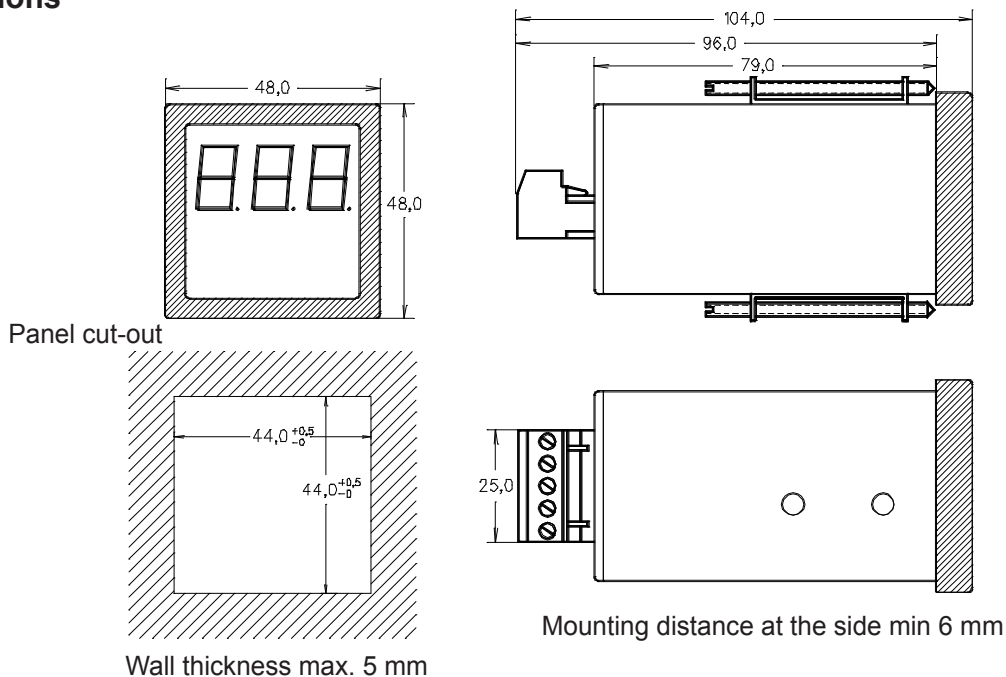

Connection diagram

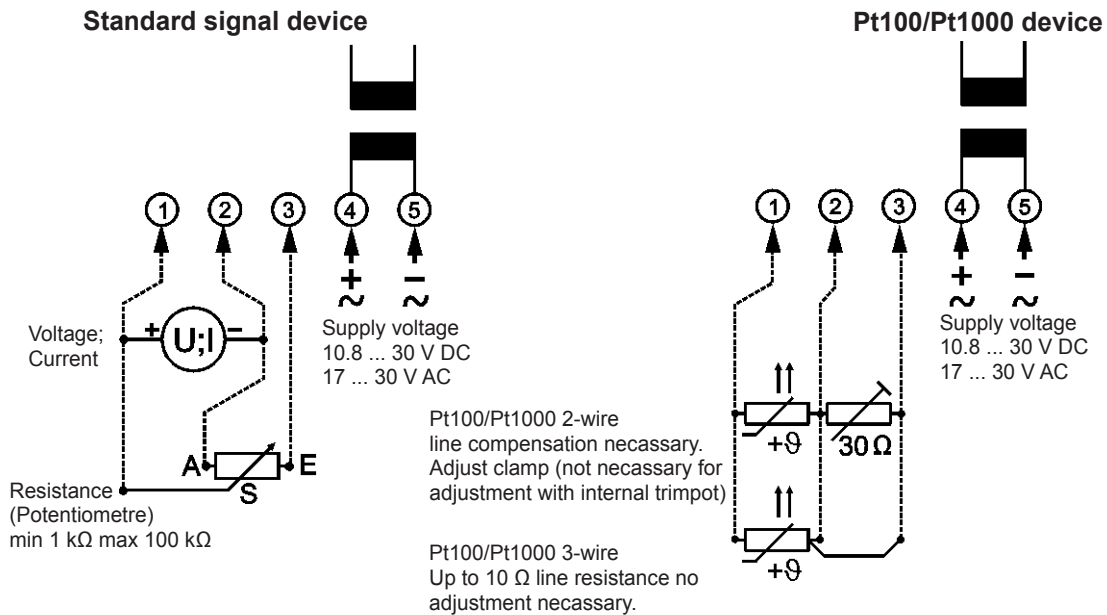

Side view

Function of the DIP-switches S4 ... S6

S4 ON → not used

S5 ON → 2 decimals (display *888*)

S6 ON → 1 decimals (display *888*)

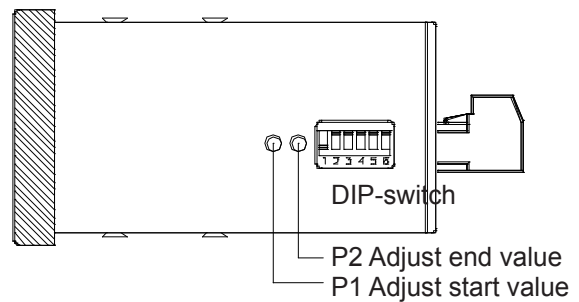

Input configuration (standard signal device)

Eingang	S1	S2	S3
0 ... 2,5 V DC	OFF	OFF	OFF
2 ... 10 V DC	ON	OFF	ON
0 ... 10 V DC	ON	OFF	OFF
4 ... 20 mA	OFF	ON	ON
0 ... 20 mA	OFF	ON	OFF
0 ... 1/100kΩ	OFF	OFF	OFF

◀ delivery configuration

Input configuration (Pt100)

Measr. range [°C]	S1	S2	S6
-19,9 ... 99,9	ON	OFF	ON
-100 ... 600	OFF	ON	OFF
DIP-switch S3, S4, S5 always OFF			

Adjustment range

	Standard signals	Temperature (Pt100/Pt1000)
Start value	-199 ... 999 Digit	± 10/5°C
End value	0 ... 999 Digit	90 ... 110%

A special adjust instruction for the standard signal device device is a part of delivery.

Ordering code

DP4848A - 1. - 2. - 3. - 4.

With unit, please state in cleartext

1. Display

3	3-digit	LED red	14.2 mm
4	3-digit	LED green	14.2 mm

2. Input

10	Industry standard signal
20	Custom input (on request)
50	Pt100
55	Pt1000

3. Protection

1	IP54
2	IP65

4. Unit (appears on the face plate)

Adjustment instructions Digital Panelmeter DP 4848A

Multi purpose device

To adjust the DP4848A you do not need any measuring instrument or simulator. Only a 2mm-screwdriver is necessary.

There are two kinds of measurement ranges to adjust:

1. Display initial value = 0 → please proceed to the item A).
2. Display initial value ≠ 0 → please proceed to the item B).

Point A Display initial value = 0

- ❶ Disconnect signal wiring from terminal 1... 3.
Connect supply voltage and Power up.

- ❷ Display zero adjust

Input configuration

S1	S2	S3
ON	OFF	OFF

Adjust display with P1 to 000

Display zero adjust

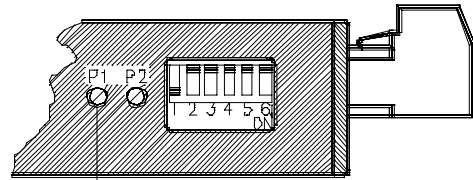

- ❸ Display final value adjust (span)

Input configuration

S1	S2	S3
OFF	OFF	OFF

Link between terminal 1 and 3.
Display adjust with P2 to the final value.

Display span adjust

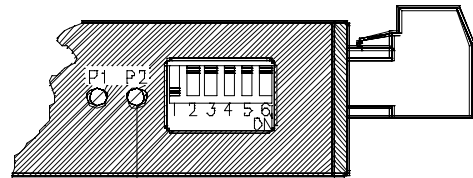

- ❹ Configure with DIP-switches S1 ... S3 to the wanted input signal (see table).
Activate decimal point with DIP-switch S5 ... S6 (if necessary).
Connect the signal at terminals 1 ... 3.

Input	S1	S2	S3
0 ... 2.5V DC	OFF	OFF	OFF
2 ... 10V DC	ON	OFF	ON
0 ... 10V DC	ON	OFF	OFF
4 ... 20mA	OFF	ON	ON
0 ... 20mA	OFF	ON	OFF
0 ... 1/100kΩ	OFF	OFF	OFF

Function of DIP-switches S4-S6
S4=ON ⇒ not installed
S5=ON ⇒ display 8.88
S6=ON ⇒ display 88.8

- ❺ End of adjustment

Point B Display initial value ≠ 0

- ❶ see page 1
- ❷ see page 1
- ❸ Adjust display range

Eingangskonfiguration	S1	S2	S3
	ON	OFF	OFF

Link between terminal 1 and 3.
 Adjust display with P2 to 1/4 of the span
 (see example).

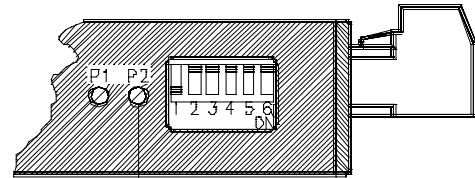

Adjust 1/4 of the span

Example: display range -120 ... +180 → span = 300 digit →
 adjust 1/4 of the span = $300/4 = 75$ digit

- ❹ Adjust initial value

Input configuration as point 3.
 Remove link from terminal 1 to 3.
 Adjust display with P1 to the initial value
 (in the example -120 Digit).

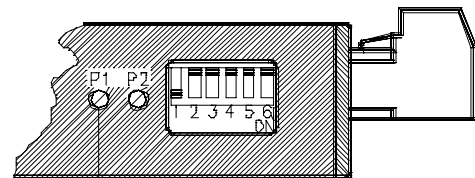

Display zero adjust

- ❺ Check display final value

Eingangskonfiguration	S1	S2	S3
	OFF	OFF	OFF

Link between terminal 1 and 3.
 Check final value (in the example 180 Digit)
 and if necessary, fine adjust with P2.

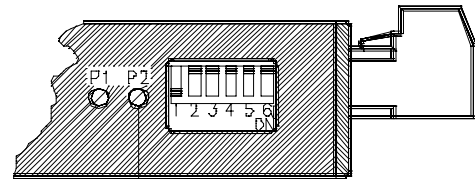

Display span adjust

- ❻ Repeat step ❹ and ❺ until no more correction is necessary.
- ❼ Configure input with DIP-switch S1 ... S3 to the wanted input signal (see chart page 1).
 Activate decimal point with DIP-switch S5 ... S6 (if needed).
 Connect the wires to terminal 1... 3.
- ❽ End of adjustment.