

Frequency-Analog Transmitter FT 500

Frequency measuring range from 0 ... 0.01 Hz up to 0 ... 20 kHz

Features

- Start value and end value programmable
- Input for 24 V proximity switch, switching contact and Namur proximity switch
- Transmitter supply , 20V DC
- Outputs 0/4 ... 20 mA, simultaneously 0/2 ... 10 V DC
- Full 3-port isolation
- Supply voltage 10 ... 30 V AC/DC or 85 ... 265 V AC
- Power-on LED
- 22,5 mm case for DIN rail mounting



General information

Frequency transmitter FT 500 are used to convert an impulse frequency range into industry standard signals. The transmitter accepts impulses from proximity switch, contact switch, light barriers and Namur proximity switches. Start- and end value will be programmed with 5 rotary switches. Increasing or decreasing output characteristic is also programmable.

Short information

Range switches	start and end value will be programmed with 2 rotary switches each. An additional switch selects the multiplier.
Watch-dog	watching program running and provides auto-reset in case of error.
Current output	maximum burden 1 kΩ

Technical data

Power supply

Supply voltage	: 85 ... 265 V AC or 10 ... 30 V AC/DC
Frequency	: 47 ... 63 Hz
Power consumption	: < 4 VA
Operating temperature	: -10 ... +60 °C (14 ... 140 °F)
Rated voltage	: 500 V _{rms} acc to VDE 0110 group 2 between input/output/supply voltage
Test voltage	: 4 kV- between input/output/supply voltage
CE -conformity	: EN55022, EN60555, IEC61000-4-4/5/11/13

Measuring input

Frequency range	: 0 ... 0.01 Hz / 20 kHz
Pulse cycle	: min. 20 µs (electronic) or min. 5 ms (contact)
Start value	: adjustable 0 ... +25 %
End value	: adjustable -15 ... + 5 %
Impulse input (terminal 2, 3)	: low- signal -30 V ... +3 V, high- signal +10 V ... +35 V
Input resistance	: R _i > 10 kΩ
Transmitter supply (terminal 1)	: approx. 20 V DC, short circuit proof approx. 25 mA
Namur input (terminal 4, 5)	: acc. to DIN 19234, Namur
Input resistance	: approx 1 kΩ

Outputs

Current output	: 0 ... 20 mA, 4 ... 20 mA switch selectable, burden ≤ 1 kΩ
Voltage output	: 0 ... 10 V DC, 2 ... 10 V DC load max. 10 mA, short circuit proof (simultaneously to the current output 5 mA)
Accuracy	: 0.1 % to the measuring end value
Temperature coefficient	: 0.01 %/K
Rise time (t ₉₀)	: < 130 ms

Case	: Standard case of polycarbonate 8020 UL 94 V-1
Weight	: approx. 140 g
Connection	: screw terminals with cover plate, max. 2.5 mm ²
Protection	: case IP 30, terminal IP20 acc. to German BGV A3

Configuration of the frequency measuring range

On the right side of the case are 5 rotary switches accessible to set the measuring range. The means of the positions are the following: Rotary switch S3, S4 for start value; S5, S6 for end value, switch S7 defines the multiplier.

Example 1

Range : 0 ... 15Hz
Switch position : 0-0-1-5-3

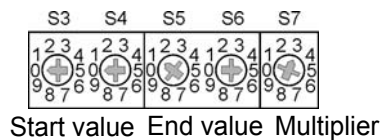

Example 2

Range : 1200 ... 7800 Hz
Switch position : 1-2-7-8-5

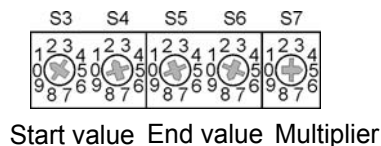

Multiplier

1	0.01 Hz
2	0.1 Hz
3	1 Hz
4	10 Hz
5	100 Hz
6	1 kHz
7	0.01 Hz debounced
8	0.1 Hz debounced
9	1 Hz debounced
0	Simulation mode

Configuration output

Output	Switch S1 (0/4 ... 20mA)
0 ... 20 mA / 0 ... 10 V	off
4 ... 20 mA / 2 ... 10V	on

Limiting value mode

When frequency setting of start and end value is identical, the output jumps from minimum to maximum level if the input frequency exceeds the setpoints.

Example

Frequency limit : 450 ... 450 Hz
 45 ... 45 x 10
 Switch position : 4-5-4-5-4

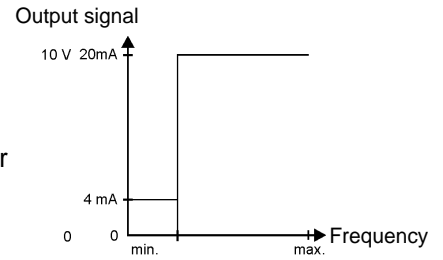
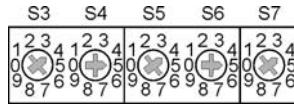

Decreasing aoutput characteristic

Example

Range : 0 ... 3.4 Hz
 00 ... 34 x 0.1
 Switch position : 3-4-0-0-2

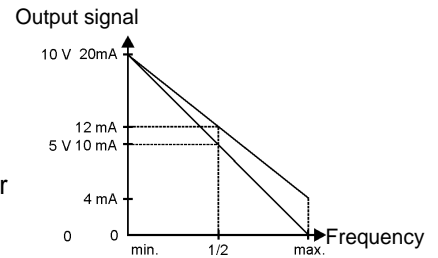
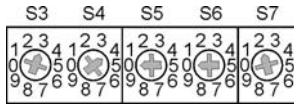

Simulation mode (S7=0)

This mode is only for testing the min. and max. output without any input signal.

S2=on; the output is maximum value; (S2=off) the output is minimum value.

SIM (S2)	Output
on	End value (20 mA, 10 V)
off	Start value (0/4 mA, 0/2 V)

Connection diagram

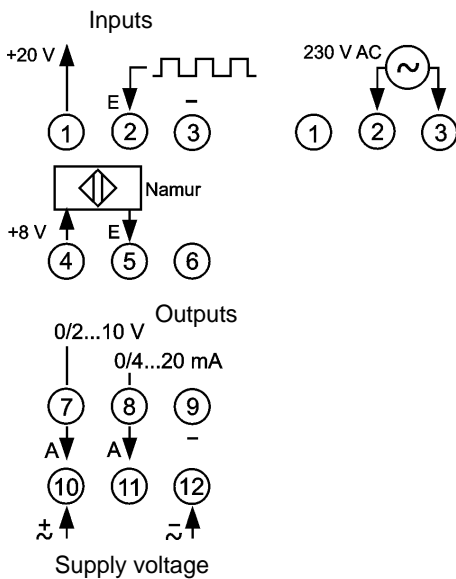

Frontpanel controls

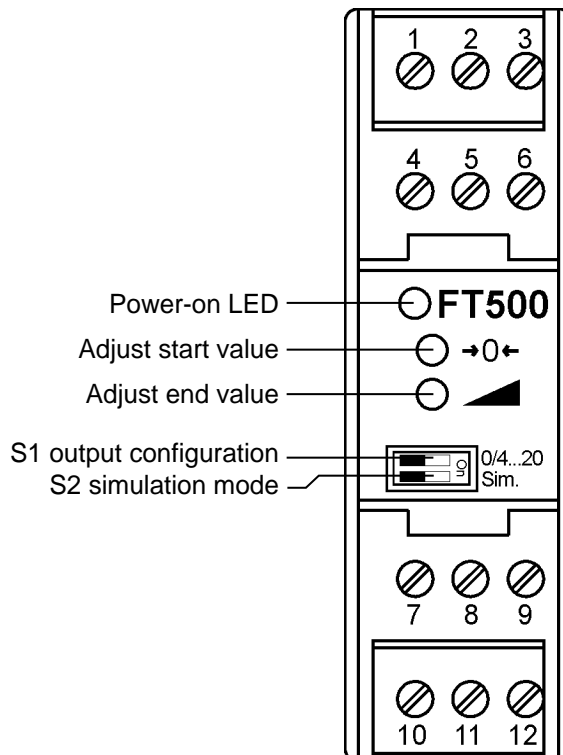

Dimensions

