

Productivity-Meter PR 9648

Speed - flow - synchronism - slip - passing time - revolution per time

Features

- LED-display, 14.2 mm red
- Display range ± 99999 digit
- 0 ... 3 decimal points programmable
- 2 digital inputs for summation, difference, ratio and product measurement
- Hold-input
- Integrated transmitter-supply 24/8 V DC
- Max. 4 outputs, SPDT relay or transistor
- Display conversion programmable
- Isolated analog output, 0/4 ... 20 mA and 0/2 ... 10 V DC
- Front protection IP65



General

The Productivity-Meter PR9648 analyses impulse rates, representing a speed, flow, passing time or revolutions per time. The displayed values therefore always refer to a determined time unit and represent productivity. There are extensive functions programmable (see page 6). Since impulses and unit of a displayed value can take any relation, the device offers extensive conversion possibilities.

Short information

Programming	Parameters are programmed via front-side membrane keypad
Transmitter-supply	The integrated transmitter supply allows direct connection of pnp initiators, light barriers, mechanical switch contacts, proximity switches, rotary encoder (24 V DC) and Namur initiators (8 V DC).
Input prescaler	An input prescaler has separate programming function for input A and B.
Display conversion	A separate programmable divisor and factor makes the display adaptable as required.
Alarm outputs	Switching performance min. or max., hysteresis, on-delay time and off-delay time are programmable in range from 1 s up to 9 h.
Analog output	Proportional to the display value an isolated analog output signal 0 ... 20 mA/0 ... 10 V DC or 4 ... 20 mA/2 ... 10 V DC can be generated. Start value and end value are programmable. Output changes automatically from current signal to voltage signal, depending on burden.
Hold function	Display freezes by control input level 24 V DC or voltage free contact (see page 3).

Technical data

Power supply

Supply voltage	: 230 V AC $\pm 10\%$; 115 V AC $\pm 10\%$, 24 V AC $\pm 10\%$ or 24 V DC $\pm 15\%$	
Power consumption	: max. 3.5 VA	
Operating temperature	: -10 ... +55 °C; 14 ... 131 °F	
Rated voltage	: 250 V~ acc. to VDE 0110 between input/output/supply voltage over-voltage categoric III	
Test voltage	: 4 kV=, between input/output/supply voltage	
CE-conformity	: EN55022, EN60555, IEC61000-4-3/4/5/11/13	

Input

PNP input	: Ri = 6.3 k Ω	level: < 4 V low; > 8.5 V high; Hysteresis > 2.5 V, max. 35 V DC
Namur input	: Ri appr. 1 k Ω (<4 mA)	level: < 1 mA low; >2.2 mA high; Hysteresis > 0.5 mA max. 35 V DC
Impulse frequency	: Input A or B = 0.1 Hz ... 15 kHz, A and B together = 0.1 Hz ... 8 kHz, switch contact = 0.1 Hz ... 30 Hz, 2-channel rotary encoder = 0.1 Hz ... 10 kHz;	
Min. Impulse width	: Electronic impulse 50 μ s, switch contact 5 ms	
Time base	: Seconds, minutes or hours	
Accuracy	: $\leq 0.003\%$ ± 1 Digit	
Hold input	: 24 V DC or switching contact	
Transmitter supply	: 8 V DC (Namur), 24 V DC (PNP), Ri appr. 150 Ω , max. 50 mA (max. 25 mA with 4 relay outputs)	
Display	: LED red, 14.2 mm	
Display range	: -99999...999999 Digit, leading zero suppression	
Parameter display	: LED 2-digit red, 7 mm (parameter - and output indicator)	

Output

Relay	: SPDT < 250 V AC < 250 VA < 2 A, < 300 V DC < 50 W < 2 A	
Transistor	: max. 35 V AC/DC, max. 100 mA, short circuit protected	
Analog output	: 0/4 ... 20 mA burden $\leq 500 \Omega$; 0/2 ... 10 V burden $> 500 \Omega$, isolated Automatic output changing (burden dependent)	
-Accuracy	: 0.1 %; TK 0.01 %/K	

Panel case

Dimensions	: DIN 96x48 mm, material PA6-GF; UL94V-0	
Weight	: max. 390 g	
Electrical connection	: Clamp terminals, 2 mm ² single wire, 1,5 mm ² flexible wire, AWG14	
Protection	: Front IP65, terminals IP20, fingersafe acc. to German BGV A3	

Dimensions

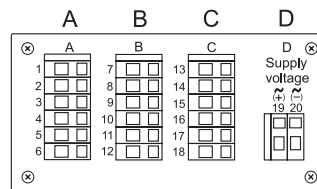
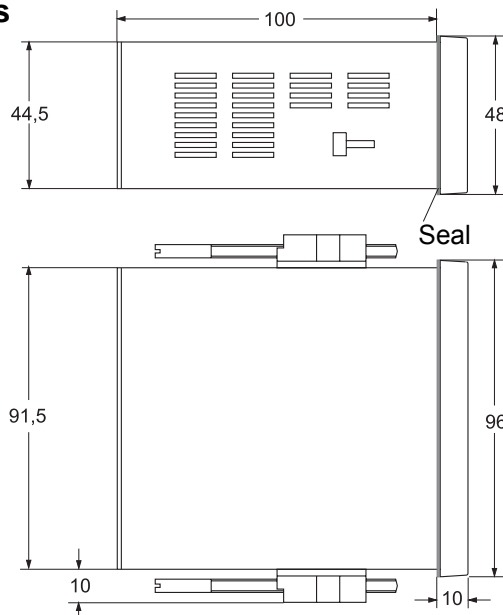

Terminal strip position

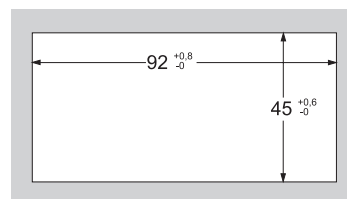

Panel cut-out acc. to
DIN 43700-96x48

Connection diagrams

Terminal strip A

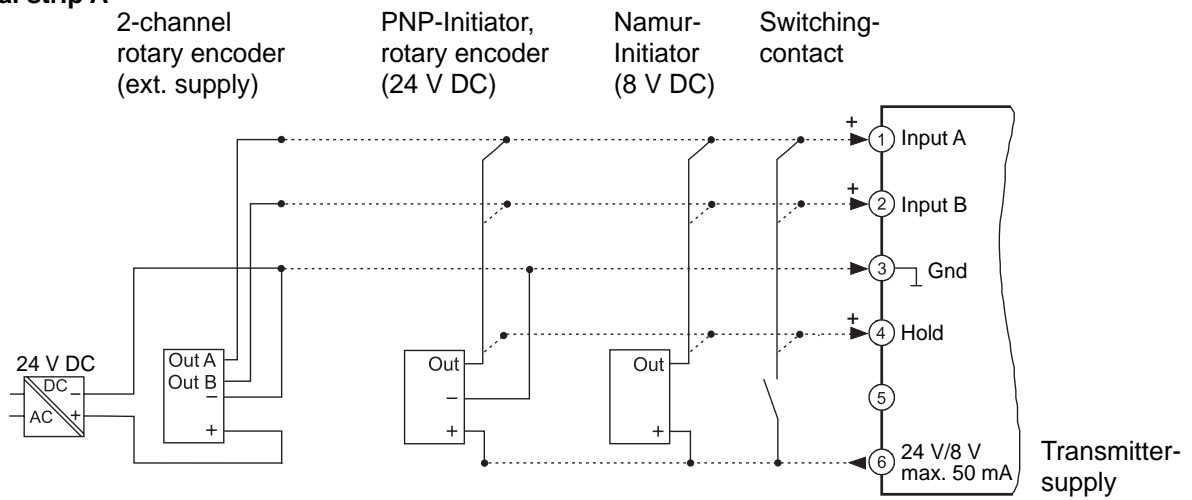

Terminal strip B (varies with version)

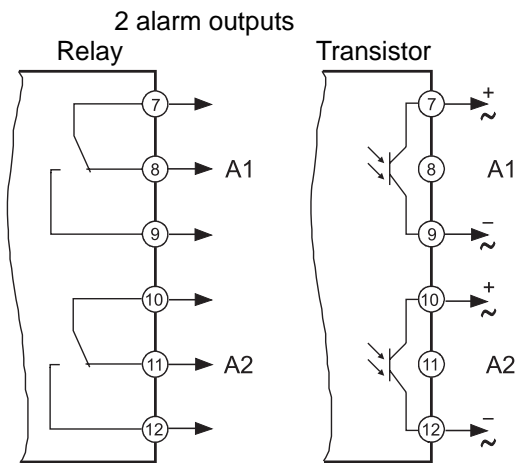

Terminal strip C (varies with version)

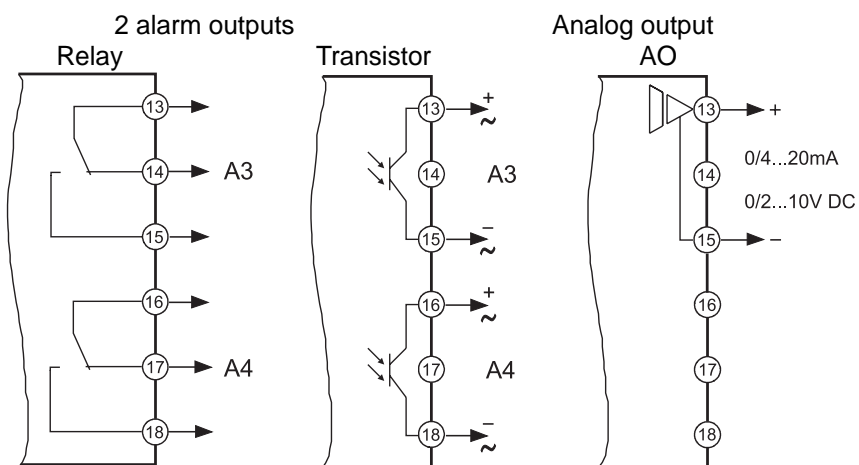

Terminal strip D supply voltage (varies with version)

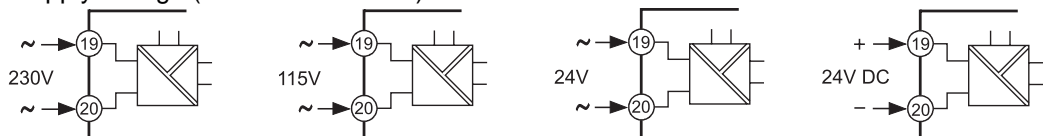

Controls and indicators

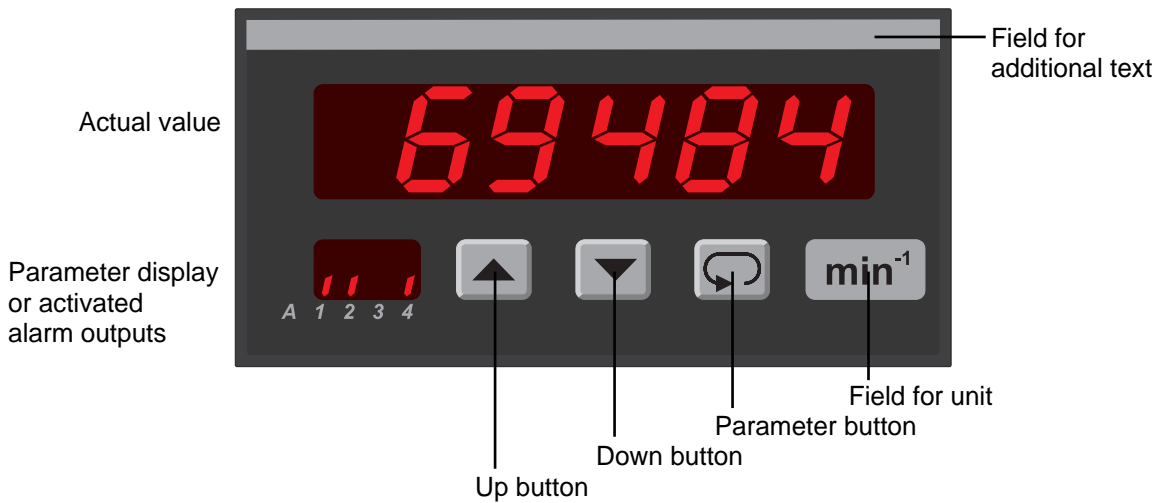

Description

Operating of the device is arranged in 2 levels. The requested parameter can be called by button . For selections within a parameter or for entering data, use buttons and .

Button combinations:

- + one parameter back
- + setting parameter to zero or minimum value

After power-on the device is located in the **Working level**. Set points of the alarm outputs can be programmed if they are available.

Pressing the button for more than 2 seconds, activates the **Configuration level**. Now all the parameters which define the function of the device can be programmed. E.g. the switching performance of the alarm outputs, measuring input and the analog output.

After finishing the configuration or when no button was pushed for more than 2 minutes, the program returns to the Working level. Leaving the Configuration level is possible at any time by pressing the button for more than 2 seconds.

Parameter display as status indicator for the alarm outputs A1-A4.

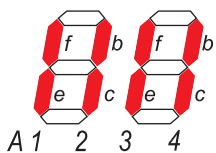

Segments f (A1 / A3) and/or b (A2 / A4) are flashing with 2 Hz, when delay time is active.

Segments e (A1 / A3) or c (A2 / A4) are output indicators.

Error messages:

PE Reading this symbol in the parameter display a parameter failure has been occurred. The display flashes. When pushing one of the buttons the error code will be deleted and the device is running with the factory programmed parameters. Configuration and function of the device must be checked. If error occurs again, please ship the device to factory for repair service.

Loc Programming lock active. See configuration page 9.

oF Overflow

Start-up note: The device has to be configured, before it can be used

⇒ see page 6

Notes to representation



Parameter is only displayed when configured





















Parameter is only displayed when feature is included (see order code)

Please Note: All parameters can be called if they are not blocked by other programmed parameters and if they are available. **Factory settings** are shown in the display.

Working level

Button	Display	Description
		Actual value
		Output indication (only if installed and activated).
		Max. peak reading. Reset with buttons or , and at every power off.
		Min. peak reading. Reset with buttons or , and at every power off.
		Setpoint output A1. Setting possible from - 99999 ... 99999 Digit with buttons and .
		Setpoint output A4. Setting possible from - 99999 ... 99999 Digit with buttons and .

Configuration

Button	Display	Description (Display graphic shows factory settings)
 Press 2 s	<div style="border: 1px solid black; padding: 5px; display: inline-block;"> 1 A-b <hr/> <i>F_u</i> </div>	Function: Input configuration <i>A - b</i> : A up, B down <i>A u. b</i> : A up, B up <i>9 0 0 1 d</i> : rotary encoder <i>b r R</i> : ratio or passing time (⇒ see page 10) <i>A - b r b</i> : percentage of deviation (A-B)/B x 100 <i>b - A r b</i> : percentage of deviation (B-A)/B x 100 Selection with buttons  and  .
	<div style="border: 1px solid black; padding: 5px; display: inline-block;"> 2 L 0 <hr/> <i>I F</i> </div>	Input frequency <i>L 0</i> : ≤ 30 Hz, for switching contacts <i>H 1</i> : ≤ 15 kHz, for electronic outputs Selection with buttons  and  .
	<div style="border: 1px solid black; padding: 5px; display: inline-block;"> 3 ! <hr/> <i>d R</i> </div>	Prescaler input A Setting possible from <i>!</i> ... <i>9999</i> digit with buttons  and  . (only every n th impulse is counted)
	<div style="border: 1px solid black; padding: 5px; display: inline-block;"> 4 ! <hr/> <i>d b</i> </div>	Prescaler input B Setting possible from <i>!</i> ... <i>9999</i> digit with buttons  and  . (only every n th impulse is counted)
	<div style="border: 1px solid black; padding: 5px; display: inline-block;"> 5 o F F <hr/> <i>ε b</i> </div>	Constant input B Setting possible from <i>- 99999</i> ... <i>o F F</i> ... <i>99999</i> digit with buttons  and  . (<i>o F F</i> = no function) Input B is deactivated. Input signal will be replaced by Constant <i>ε b</i> . This constant enables to measure e.g. the slippage of a motor, the deviation from a reference value or the passing time in a continuous heater.
	<div style="border: 1px solid black; padding: 5px; display: inline-block;"> 6 U=24 <hr/> <i>i n</i> </div>	Transmitter supply/input level <i>U = 2 4</i> : 24V DC for pnp-initiatoren <i>U = 8</i> : 8V DC for Namur-initiatoren* (* with ext. 5V supply also suitable for TTL-signals) <i>ε ε 5 ε</i> : only for factory settings Selection with buttons  and  .
		

continue
page 7

Button Display Description (Display graphic shows factory settings)

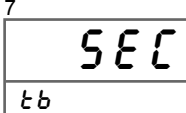
↓  Time base
hour : hours (h⁻¹)
min : minutes (min⁻¹)
SEC : seconds (s⁻¹)
 Selection with buttons ▲ and ▼.

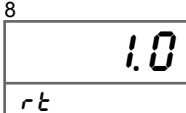

↓  Refresh time (displayed time)
 Setting possible from 0.1 ... 9.9 seconds
 with buttons ▲ and ▼.
 Maximum display accuracy with will be reached :
 $r t \geq (\text{max. display time in digit}) \times 0.000024 \text{ s}$
 Example: max. display value 1200.0
 $r t = 12000 \times 0.000024 = 0.288\text{s} \Rightarrow r t \geq 0.3 \text{ s}$

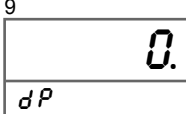

Note:
 At minimum 2 impulses must run the input within one refresh cycle (refresh time)

↓  Decimal point position
Auto (floating point)
.000
.00
.0
0.
 Selection with buttons ▲ and ▼.

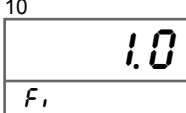

↓  Digital filter
off
on
 Selection with buttons ▲ and ▼.

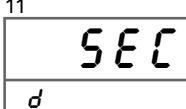

↓  Divisor for display
 Setting possible from 1 ... 9999 Digit
 with buttons ▲ and ▼.

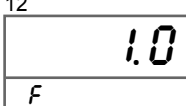

↓  Factor for display
 Setting possible from 1 ... 9999 Digit
 with buttons ▲ and ▼.

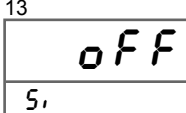

↓  Sign
off : no sign for measuring value and parameter
on : with sign; the output activation referring belongs to the sign
 (depending on direction of movement)
 Selection with buttons ▲ and ▼.



continue
 page 8

Button	Display	Description (Display graphic shows factory settings)
↓	<div style="border: 1px solid black; padding: 5px; width: fit-content;"> <div style="text-align: right; margin-bottom: 5px;">14</div> <div style="text-align: center; font-size: 24px; font-weight: bold;">oFF</div> <div style="border-top: 1px solid black; padding-top: 2px;">A1</div> </div>	Switching performance output A1 <i>oFF</i> : no action <i>oOn</i> (min) : continous contact: on-off <i>oOn</i> (max) : continous contact: off-on Selection with buttons ▲ and ▼.
↺		
↓	<div style="border: 1px dashed black; padding: 5px; width: fit-content;"> <div style="text-align: right; margin-bottom: 5px;">15</div> <div style="text-align: center; font-size: 24px; font-weight: bold;">0</div> <div style="border-top: 1px solid black; padding-top: 2px;">A1</div> </div>	Setpoint output A1 Setting possible from - 99999 ... 99999 digit with buttons ▲ and ▼. Decimal points only displayed if a fixed decimal point was programmed
↺		
↓	<div style="border: 1px dashed black; padding: 5px; width: fit-content;"> <div style="text-align: right; margin-bottom: 5px;">16</div> <div style="text-align: center; font-size: 24px; font-weight: bold;">20</div> <div style="border-top: 1px solid black; padding-top: 2px;">A1</div> </div>	Hysteresis of alarm output A1 Setting possible from 1 ... 999999 digit with buttons ▲ and ▼. <i>Auto</i> mode without decimals.
↺		
↓	<div style="border: 1px dashed black; padding: 5px; width: fit-content;"> <div style="text-align: right; margin-bottom: 5px;">17</div> <div style="text-align: center; font-size: 24px; font-weight: bold;">00.00.00</div> <div style="border-top: 1px solid black; padding-top: 2px;">t1</div> </div>	Switch-on delay time alarm output A1. Setting possible from 0.00.00 ... 9.00.00 (h.mm.ss) with buttons ▲ and ▼.
↺		
↓	<div style="border: 1px dashed black; padding: 5px; width: fit-content;"> <div style="text-align: right; margin-bottom: 5px;">18</div> <div style="text-align: center; font-size: 24px; font-weight: bold;">00.00.00</div> <div style="border-top: 1px solid black; padding-top: 2px;">t1</div> </div>	Switch-off delay time alarm output A1. Setting possible from 0.00.00 ... 9.00.00 (h.mm.ss) with buttons ▲ and ▼.
↺		

Note: The parameter settings for A2 ... A4 have to be configured the same way.

Button Display Description (Display graphic shows factory settings)

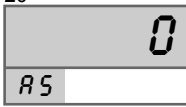
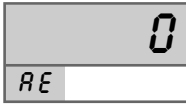
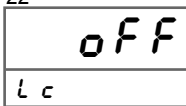
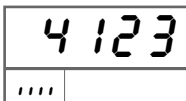
↓	¹⁹ 	Analog output 0 - 20 mA (0 - 10 V DC) 4 - 20 mA (2 - 10 V DC) The switch-over from current to voltage output is load dependent (≤ 500 Ω = current output, > 500 Ω = voltage output). Selection with buttons ▲ and ▼.
↻		
↓	²⁰ 	Start value for analog output Setting possible from - 99999 ... 99999 Digit with buttons ▲ and ▼. Decimal point only shown if programmed.
↻		
↓	²¹ 	End value for analog output Setting possible from - 99999 ... 99999 digit with buttons ▲ and ▼. With fixed decimal point programming the difference between start- and end value must be at minimum 4000 digit to get the maximum display resolution. With floating point (R u t o), parameter R 5 and R E changing automatically for best resolution. If the start value R 5 > end value R E , the output works with decreasing characteristic. Decimal points only shown if a fixed decimal point was programmed
↻		
↓	²² 	Programming lock o F F : no lock [o n F : configuration level locked A L L : all parameters locked [R L : only with analog output (for factory settings) Selection with buttons ▲ and ▼.
↻		
		Return to the working level

Measurement of passing time

Normally display value will increase with input impulse sequence. But when measuring passing time, it will be just reversed. The more pulses per time will run the input the less will be the passing time.

For measuring passing time following parameters are important:

1. Function: Input configuration
 $F_u \Rightarrow b' R$ (must be selected)
2. Constant Input B
 $\zeta b \Rightarrow$ Total number of impulses for one passing cycle. If this value >99999 Digit, input must be adapted by prescaler input A.

$$\zeta b = \frac{\text{Impulse for 1 passing cycle}}{d R} \leq 99999 \text{ digit}$$

3. Prescaler input A
 $d R \Rightarrow$ enter smallest possible value to get the maximum display range
4. Time base
 $t b \Rightarrow$ select time base

Note: If $\zeta b < 10000$ digit, it will be necessary for accuracy measurement to change following parameters:

- a. $t b$ change time base up (e.g. from s in min)
- b. ζb multiply with factor 60

If the result >99999, parameter d A must be adapted (see point 2.)

5. Refresh time
 $r t \Rightarrow$ Within the refresh interval at least 2 input impulses must run the input.

Example

Calculating the passing time of a continue drying oven in minutes, with one decimal point.

Following data are known:

Length of oven	30m
Distance per one resolution of the measuring shaft	0.1m
Number of impulses per one resolution of the measuring shaft	500
Time base	min
Decimal point position	0.0
Sensor type	pnp-initiator

The maximum impulses for one passing cycle at input A

$$\frac{500 \text{ impulses}}{0.1\text{m}} \times 30\text{m} = 150000 \text{ impulses}$$

The maximum value for cb (with selected decimal point 0.0) could be entered is 9999.9

$$cb = \frac{150000}{dA} \leq 99999 \text{ Digit}$$

If the parameter dR is selected with value 20, the result as shown:

$$cb = \frac{150000}{20} = 7500.0 = (75000 \text{ Digit})$$

Configuration for this measuring task:

F_u : b r R
 dR : 20
 db : 1
 cb : 7500.0
 ln : U=24
 tb : pnp
 rt : 1
 dP : .0
 F_i : o f f
 d : 1
 f : 1
 S_i : o f f

Ordering code

PR9648 - 1. - 2. - 3. - 4. - 5. - 6. - 7.

1. Terminal strip A

1 2 configurable impulse inputs,
integrated transmitter supply,
display conversion programmable,
hold input

2. Terminal strip B

00 not installed
2R 2 alarm outputs relay
2T 2 alarm outputs transistor

3. Terminal strip C

00 not installed
2R 2 alarm outputs relay
2T 2 alarm outputs transistor
AO Analog output 0/4 ... 20 mA or 0/2 ... 10 V DC
isolated

4. Terminal strip D supply voltage

0 230 V AC ± 10 % 50-60 Hz
1 115 V AC ± 10 % 50-60 Hz
4 24 V AC ± 10 % 50-60 Hz
5 24 V DC ± 15 %

5. Option

00 without option
01 min- and max-peak-hold

6. Unit (on the panel front)

7. **Additional text** (on the additional text field on the panelmeter,
maximum 3 x 90mm WxH)