

Resistance-Transmitter RT 500

Resistance range from 0...50 Ω to 0...100 kΩ

Features

- 12 Bit AD/DA processor technology with 250 Hz realtime execution
- Teach-in programming for initial and final value
- 2- and 3-wire connection
- Output for 0/4 ... 20 mA, simultaneous 0/2 ... 10 V
- Increase or decrease output characteristic programmable
- Operation mode indicated by 2-color LED
- Supply voltage 85 ... 265 V AC or 10 ... 30 V AC/DC
- 22.5 mm case for DIN rail mounting



General information

RT500 transmitter converts a resistance- or potentiometer signal into industry standard signals. Initial and final value may be in the range of 0...100 kOhm. Easy programming by Teach-in. The measuring range will be selected automatically. The input circuit is designed in 3-wire technology and can provide compensation of the line resistance. The linear output-signal is generated between minimum and maximum input resistance.

Short information

Programming	input programming and output configuration is selected with DIP switches at the front panel
Watch-dog	watches program running and provides auto-reset in case of an error
Data memory	protection against power failure
Current output	maximum burden 1 kΩ

Technical data

Power supply

Supply voltage	: 85 ... 265V AC or 10 ... 30V AC/DC
Frequency AC	: 47 ... 63 Hz
Power consumption	: < 3VA
Operating temperature	: -10 ... +50 °C
Rated voltage	: 500V \approx according to German VDE 0110 Group 3 between input, output/power supply
Test voltage	: 4 kV= between power supply and input/output
CE - conformity	: EN55022, EN60555, IEC61000-4-4/5/11/13

Input

Resistance range	: Rmax: 50 Ω ... 100 k Ω , cond.: $\Delta R \geq 0.5 R_{max}$ (lower values on request) increasing or decreasing output characteristic programmable.
------------------	---

Measuring voltage
and - current

Measuring voltage	Measuring current			
	6,25 mA	2,5 mA	250 μ A	25 μ A
1 V	100 Ω	250 Ω	2,5 k Ω	25 k Ω
2 V	-	500 Ω	5 k Ω	50 k Ω
4 V	-	1 k Ω	10 k Ω	100 k Ω

Resistance values
for maximum
resolution!

Resolution	: 600 ... 3000 digit (depends on measurement range)
Sampling frequency	: 250 Hz real-time processing
Cable resistance	: 10 Ω max. Automatic compensation in 3-wire-circuits with symmetric line-resistance

Output

Current output	: 0/4 ... 20 mA switch selectable; load \leq 1 k Ω
Voltage output	: 0/2 ... 10 V switch selectable; load 15 mA max., short-circuit-protection (simultaneous to current output 5 mA max.) Attention! No isolation between input and output!
Rise time (t_{90})	: < 8 ms
Accuracy	: < 0.2 %
Temperature coefficient	: \leq 100 ppm/ $^{\circ}$ C

Case	: standard case of polycarbonate 8020 UL94V-1
Weight	: approx. 200 g
Protection	: Case IP30, terminals IP20 finger safe acc. to German BGV A3
Connection	: screw-terminals with pressure plate max 2.5 mm 2 , wire

Programming

Programming resistance measuring range	
1	Set resistance (Rmin) at terminals 1,2,3
2	S1 ON -> RT500 stores the value of Rmin
3	-> LED flashes green = OK -> LED flashes red = error (see status LED)
4	S1 OFF
5	Set resistance (Rmax) at Terminals 1,2,3
6	S2 ON -> RT500 stores the value of Rmax
7	see point 3
8	S2 OFF -> Programming of the measuring range is now completed
9	Set with S3 the wanted output configuration

Status of the front side LED		
OFF	green	Operation mode
	red	Measuring range exceeded or break of line
	red/green flashing	Last programming invalid. Resistance value could not be stored
ON	LED off (2 sec.)	Resistance value stored
	green flashing	Measured resistance value has been stored in the EEPROM
	red flashing	The difference of the resistance is smaller than 20 ... 50% (depending on measuring range) of Rmax
	red	Measured value exceeds the max. value of 100 k Ω . Resistance value could not be stored.

Examples:

1.) Measuring range	15 ... 90 Ω
2.) Measuring range	0 ... 1 k Ω
3.) Measuring range	100 ... 200 Ω

Attention! Minimal span 0.5 Rmax

Connection diagram

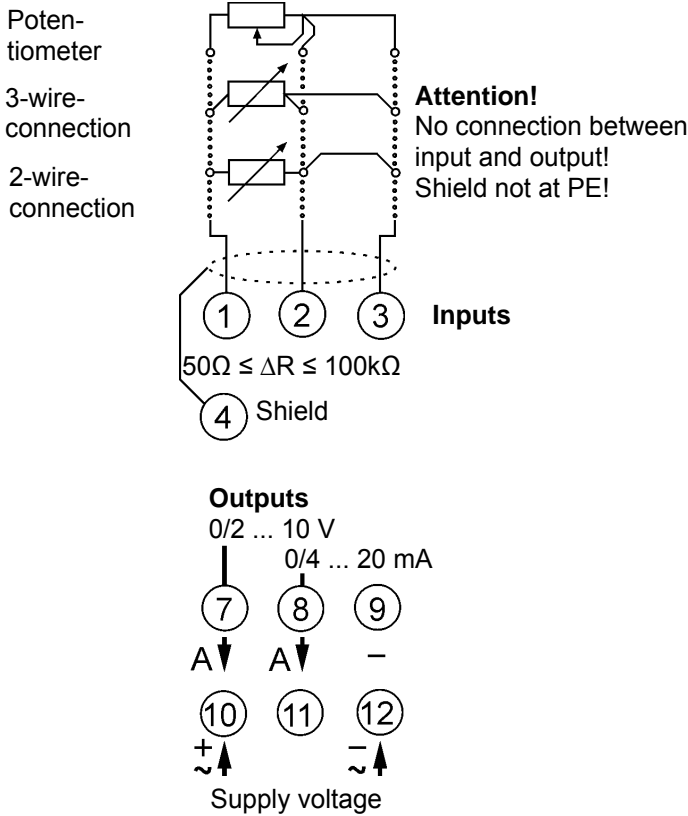

Front panel controls

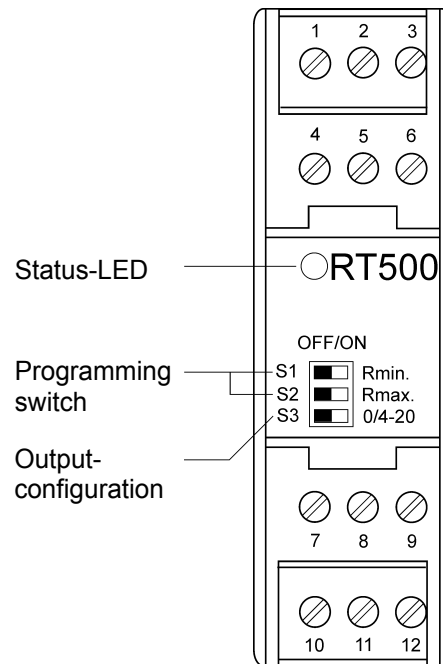

Dimensions

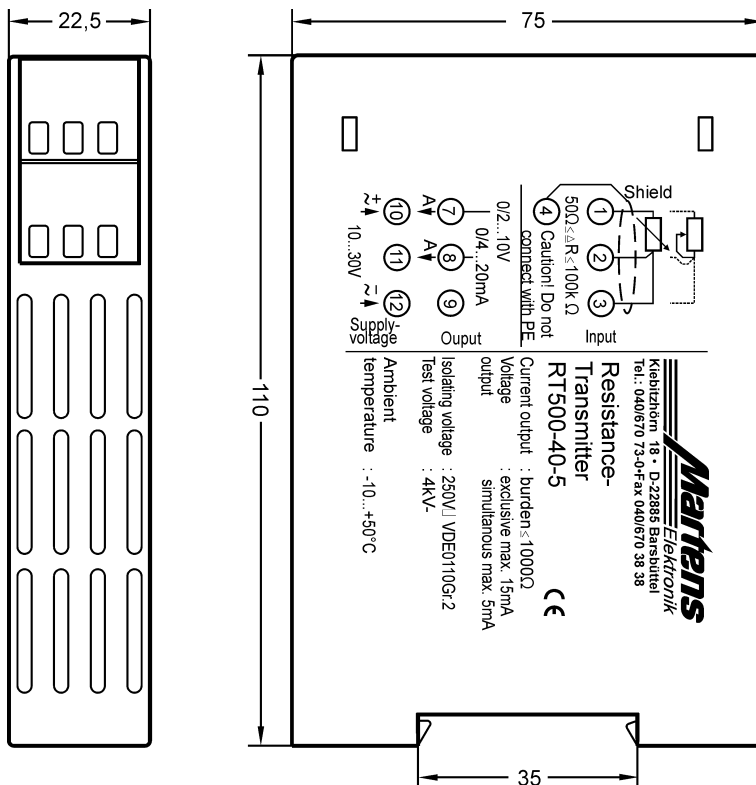

Caution!
Mounting of multiple units without distance is only permitted in horizontal orientation.

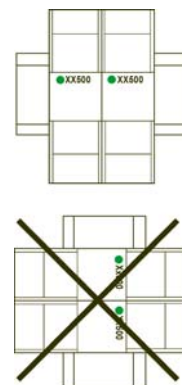

TS35 DIN rail mounting
acc. to DIN 46277 and DIN EN 50022

Ordering code

RT500 - ^{1.} - ^{2.}

1. Measuring range

40 Rmax programmable from 50 Ω up to 100 kΩ
(see examples page 2)

2. Supply voltage

0 85 ... 265 V AC
5 10 ... 30 V AC/DC

Note: Configuration is possible ex factory without extra charge.
Please state the desired data, when ordering.
E.g.: 0 ... 250 Ω or 150 ... 800 Ω