

Setpoint adjuster SG 9648

Output standard signals 0/4 ... 20 mA or 0/2 ... 10 V DC

Features

- LED-Display 14.2 mm red
- Display range $\pm 9999(0)$ digit
- Indicating range and decimal point free programmable
- Set point adjustment with front buttons or external control signals
- Set point limit programmable
- Regulating time programmable
- Max. 2 outputs SPDT relay or transistor
- Isolated analog output
0/4 ... 20 mA or 0/2 ... 10 V DC
- Front protection IP65



DIN 96x48 mm

General information

The Set point adjuster SG9648 has been designed for generating adjustable set point value signals 0/4 ... 20 mA and 0/2 ... 10 V DC. Any display value can be assigned to the respective output signal. The operator can work with real values. The adjustment speed is programmable.

Short information

| | |
|--------------------------|---|
| Programming | Parameters are programmed via front-side membrane keypad. |
| Alarm outputs | Switching performance of the alarm output is programmable as minimum or maximum function. |
| Int. setpoint adjustment | The setpoint can be adjusted with front buttons. The adjustment is running dynamically, i.e. the regulating speed increases with the operation time of the buttons. |
| Ext. setpoint adjustment | The setpoint can be adjusted with external signals. The adjustment is running dynamically or linear. In the linear adjustment mode the speed is constant, i.e. the output signal changes linear. The adjustment time is programmable from 1 to 100 s. |
| Power-on-reset | Setpoint can be set to the last stored value or to a programmed reset value. |
| External reset | The setpoint will be set to a programmed reset value. |
| Analog output | Proportional to the display value an isolated analog output signal 0 ... 20 mA/ 0 ... 10 V DC or 4 ... 20 mA/2 ... 10 V DC will be generated. The output signal is limited to the range of the minimum and maximum value. Output changed automatically from current signal to voltage signal depending on burden. |

Technical data

Power supply

| | |
|-----------------------|--|
| Supply voltage | : 230 V AC $\pm 10\%$; 115 V AC $\pm 10\%$; 24 V AC $\pm 10\%$ or 24 V DC $\pm 15\%$ |
| Power consumption | : 5 VA |
| Operating temperature | : -20 ... +55 °C (-4 ... 131°F) |
| Rated voltage | : 250V _{acc} VDE 0110 between input/output/supply voltage, degree of pollution 2, overvoltage categoric III |
| Test voltage | : 4 kV _{acc} , between input/output/supply voltage |
| CE - conformity | : EN55022, EN60555, IEC61000-4-3/4/5/11/13 |

Input

| | |
|-----------------------|--|
| Control input | : 0/24 V DC Ri 6.3 k Ω < 4 V low, > 8.5 V high, Hysteresis > 2.5 V, max. 35 V DC |
| Switch contact supply | : 24 V DC (pnp), Ri appr. 150 Ω , max. 50 mA |

Display

| | |
|------------------|--|
| Indicating range | : $\pm 9999(0)$ digit |
| Add. display | : LED 2-digit red, 7 mm (parameter - and status indicator) |

Output

| | |
|---------------|--|
| Relay | : SPDT < 250 V AC < 250 VA < 2 A, < 300 V DC < 50 W < 2 A |
| Transistor | : max. 35V AC/DC, max. 100mA, short circuit protected |
| Analog output | : 0/4 ... 20 mA burden $\leq 500 \Omega$; 0/2 ... 10 V burden > 500 Ω , isolated output changes burden dependant |
| -accuracy | : 0.1 %; TK 0.01 %/K |
| -resolution | : 12 Bit |

Panel case

: DIN 96x48mm, material PA6-GF; UL94V-0

Dimensions

: Front 96x48mm, mounting depth 100mm,

Weight

: max. 390g

Electrical connection

: Clamp terminals, 2 mm² single wire, 1.5 mm² flexible wire, AWG14

Protection

: Front IP65, terminals IP20, fingersafe acc. to German BGV A3

Dimensions

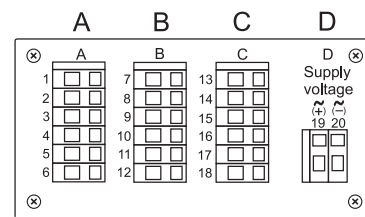
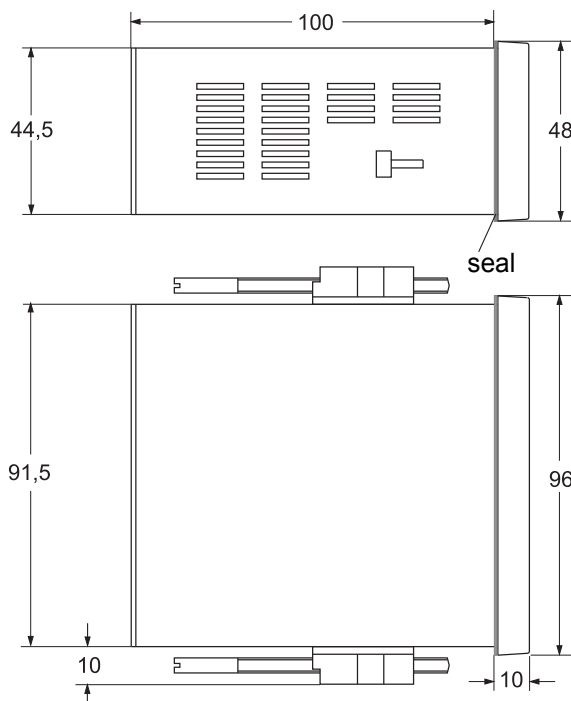

Position terminal strips

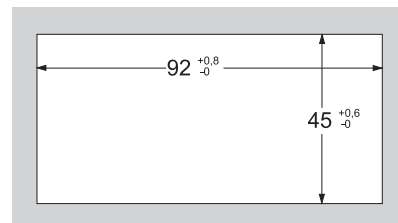

Panel cut-out
DIN 43700-96x48 mm

Connection diagrams

Terminal strip A (only installed in connection with external set point adjustment)

Actuation with voltage free contacts

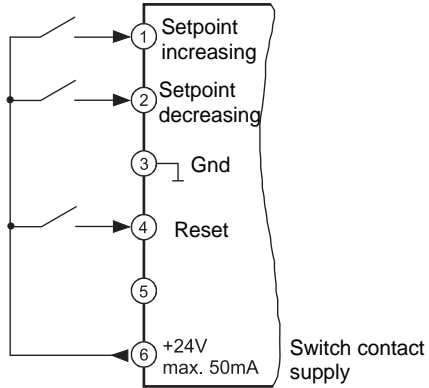

Actuation with ext. logic signals (e.g. PLC-outputs)

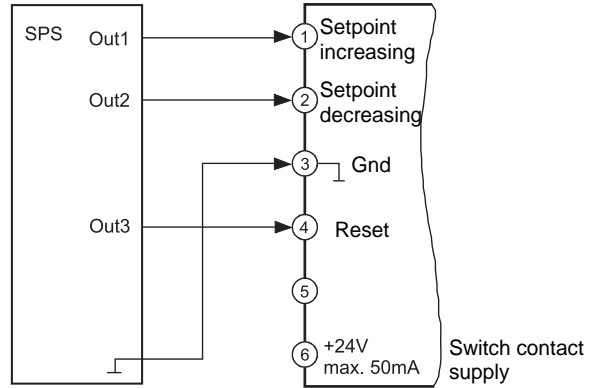

Terminal strip B (varies with version)

2 alarm outputs

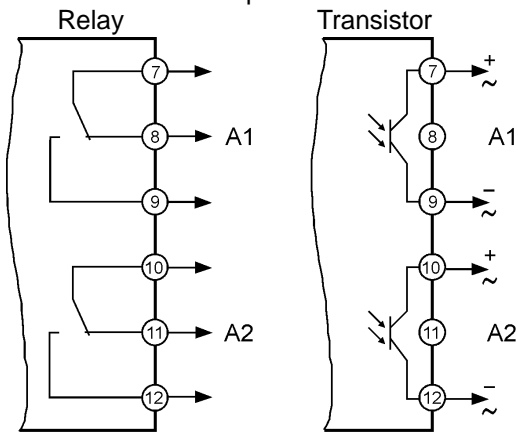

Terminal strip C (varies with version)

Analog output AO

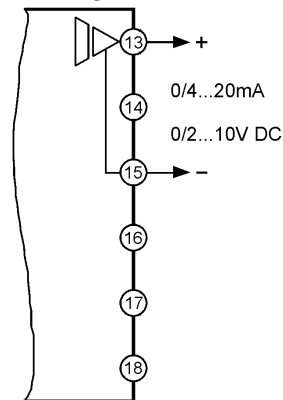

Terminal strip D supply voltage (varies with version)

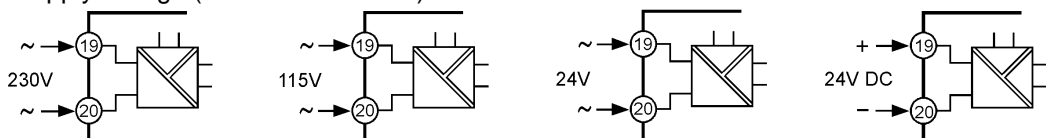

Controls and indicators

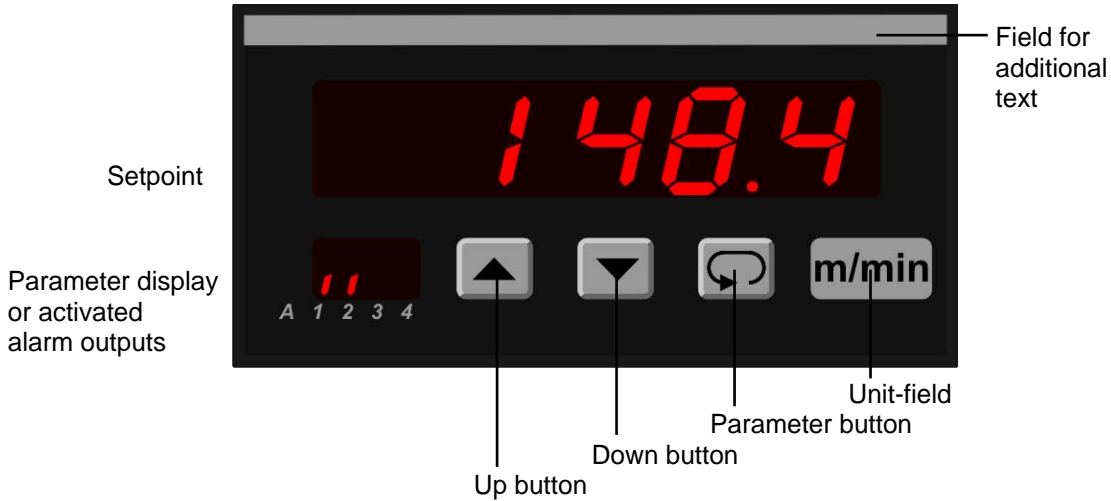

Description

Operation of the device is arranged in 2 levels. The requested parameter can be called by button . For selection within a parameter or for entering data, use button and .

Button combinations:

- + 1 parameter back
- + setting parameter to zero or minimum value

After switching on the supply voltage, the device is located in the **Working level**. Setpoint can be adjusted.

Pressing the button for more than 2 seconds, activates the **Configuration level**. Now all the parameters which defines the function of the device can be programmed.

After finishing the configuration or when no button was pushed for more than 2 minutes, the program returns to the working level. Leaving the configuration level is possible at any time by pressing the button for more than 2 seconds.

Error codes:

P E Reading this message in the parameter display a parameter failure has been occurred. The display flashes. By pressing one of the front side buttons, the error code will be deleted and a copy of the factory settings will be reloaded to the EEPROM. The device will work with the factory settings. If this copy doesn't work, please ship the device for factory repair.

Lo c Programming lock active. See configuration page 7.

o F Overflow

Start-up note:

Before the device can be used, it must be configured for the intended use.

⇒ see page 5

Notes to representation









Parameter is only displayed when configured



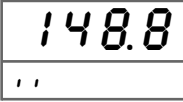
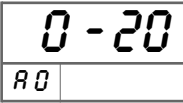

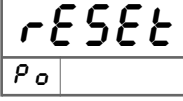

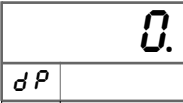
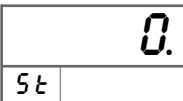





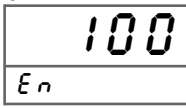

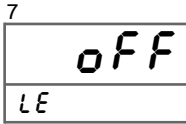

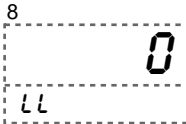

Parameter is only displayed when feature is included (see order code)

Please Note: All parameters can be called if they are not blocked by other programmed parameters and if they are available. **Factory settings** are shown in the display.

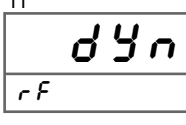
Configuration

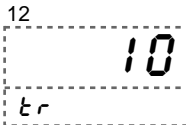
| Button | Display | Description |
|---|--|---|
|  Press 2 s |  | Actual setpoint value Setting with buttons ▲ and ▼. Output indication (only if installed and activated) |
| ↓ | 1  | Configuration of the analog output 0 - 20 mA (0 - 10 V DC) 4 - 20 mA (2 - 10 V DC) Changing from current to voltage output is load-dependent (≤ 500 Ω = current output, > 500 Ω = voltage output). Selection with buttons ▲ and ▼. |
|  | 2  | Setpoint value after power-on. rESEt = loading reset value (rE) (⇒see page 6) rESEtOr = set point stored zero-voltage safe tESEt = only for factory settings Selection with buttons ▲ and ▼. |
| ↓ | 3  | Fixed zero 0, e.g. 3690+0 nO, YES Selection with buttons ▲ and ▼. |
|  | 4  | Decimal point position. if FO = nO : 0.0.00 if FO = YES : 0.0.000 Selection with buttons ▲ and ▼. |
| ↓ | 5  | Start value for indicating range (setpoint) Setting possible from -9999(0) ... 9999(0) Digit with buttons ▲ and ▼. |
|  | | |



continue
page 6

| Button | Display | Description |
|---|--|--|
|  | ⁶  | End value for indicating range (set point) Setting possible from -9999(0) ... -9999(0) digit with buttons ▲ and ▼. If the value $S_t > E_n$, the output works with a decreasing characteristic. |
|  | | |
| | ⁷  | Setpoint limit <i>on - off</i> Selection with buttons ▲ and ▼. |
|  | | |
| | ⁸  | Setpoint low limit Setting possible from -9999(0) ... -9999(0) digit with buttons ▲ and ▼. |
|  | | |
| | ⁹  | Setpoint high limit Setting possible from -9999(0) ... -9999(0) digit with buttons ▲ and ▼. |
|  | | |
| | ¹⁰  | Reset value, after power-on or reset. More details see parameter P_0 page 5 Setting possible from -9999(0) ... -9999(0) digit with buttons ▲ and ▼. |
|  | | |
| | ¹¹  | Adjustment function (only external adjustment) L_{in} = the setpoint adjustment is running linear in range of the programmed time (see following parameter) dyn = the setpoint adjustment is running dynamically. The regulating speed increases with operation time. Selection with buttons ▲ and ▼. |
|  | | |
| | ¹²  | Adjustment time increasing ($5t \dots E_n$) Setting possible from 1 ... 100 s with buttons ▲ and ▼. |
|  | | |
| | ¹³  | Adjustment time decreasing ($E_n \dots 5t$) Setting possible from 1 ... 100 s with buttons ▲ and ▼. |
|  | | |

continue
page 7

Button**Display****Description**

14

R I

Switching performance output A1
 Function *oFF*; *oNL* (min); or *oNJ* (max).
 If activated the start value will be loaded for set point.
 Selection with buttons  and .





15

R I

Setpoint output A1
 Setting possible from *S t* (start value) ... *E n* (end value)
 with buttons  and .





16

H I

Hysteresis output A1
 Setting possible from *1* ... *9999* digit
 with buttons  and .

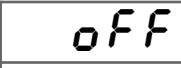
Note: Parameters for alarm output A2 has to be configured in the same way.



17

L c

Parameter lock.
oFF = no lock
C onf. = configuration level locked
R LL = configuration level and internal setpoint adjusting locked
C RL = only for factory settings
 Selection with buttons  and .

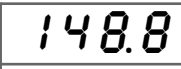

..

Return to the working level

Ordering code

SG9648 - 1. - 2. - 3. - 4. - 5. - 6. - 7.

1. Terminal strip A

- 0 Setpoint adjustment with front buttons, adjustment speed dynamically, (Power-on)-reset to the last stored value or programmed reset value.
- 1 as 0, but 2 additional control inputs for external setpoint adjustment, adjustment speed dynamically or linear programmable, the external reset input is not available.

2. Terminal strip B

- 00 not installed
- 2R 2 alarm outputs relay SPDT
- 2T 2 alarm outputs transistor

3. Terminal strip C (standard)

- AO Analog output 0/4 ... 20 mA or 0/2 ... 10 V DC isolated to the supply voltage

4. Terminal strip D supply voltage

- 0 230 V AC ± 10 % 50-60 Hz
- 1 115 V AC ± 10 % 50-60 Hz
- 4 24 V AC ± 10 % 50-60 Hz
- 5 24 V DC ± 15 %

5. Option

- 00 without option

6. Unit (on the front panel)

7. Additional text (on the lid, field for additional text, max. 3 x 90 mm, WxH)

Factory settings on request