

Universal counter UZ 9648

Counting - length measurement - metering - positioning

Features

- LED-Display 14.2mm red
- Display range -99999 ... 999999
- 0 ... 3 Decimal points programmable
- Up- and down counter function
- 2 digital inputs channel for summation and subtraction
- Integrated transmitter-supply 24/8 V DC
- Auto-reset or external reset
- Max. 4 alarm outputs, relay SPDT
- Display conversion programmable
- Isolated analog output
0/4 ... 20 mA and 0/2 ... 10 V DC
- Front Protection IP65



DIN 96x48 mm

General

The universal counter UZ9648 has been designed for field application in process control and automation. Parameters for operation mode can be programmed. The counter can be used wherever quantity processes should be measured, displayed and monitored.

Short information

Programming	Parameters are programmed via front-side membrane keypad
Transmitter-supply	The integrated transmitter supply allows direct connection of pnp initiators, light barriers, mechanical switch contacts, proximity switches, rotary encoder (24 V DC) and Namur initiators (8 V DC).
Input prescaler	Separate programmable prescaler for input channels.
Display conversion	Programmable divisor and factor makes the display adaptable for measuring applications, e.g. flow, length etc..
Alarm (Preset) outputs	Alarm outputs can be programmed as continuous contact or pulse contact. Switching performance is programmable as minimum or maximum function.
Analog output	Proportional to the display value an isolated analog output signal 0 ... 20 mA/0 ... 10 V DC or 4 ... 20 mA/2 ... 10 V DC can be generated. Start value and end value are prorammmable. Output changes automatically from current signal to voltage signal, depending on burden.

Technical data

Power supply

Supply voltage	: 230 V AC $\pm 10\%$; 115 V AC $\pm 10\%$; 24 V AC $\pm 10\%$ or 24 V DC $\pm 15\%$	
Power consumption	: max. 3.5 VA, with analog output 5 VA	
Operating temperature	: -10 ... +55 °C Standard	
Rated voltage	: 250 V AC acc. to VDE 0110 between input/output/supply voltage, degree of pollution 2, over-voltage category III	
Test voltage	: 4 kV DC, between input/output/supply voltage	
CE - conformity	: EN55022, EN60555, IEC61000-4-3/4/5/11/13	

Input

npn-input	: Ri = 6.3 k Ω	switching level: < 4 V low; > 8.5 V high; hysteresis > 2.5 V, max. 35 V DC
Namur input	: Ri appr. 1 k Ω (< 4 mA)	switching level: < 1 mA low; > 2.2 mA high; hysteresis > 0.5 mA max. 35 V DC
Counting frequency max.	: Input A or B = 15 kHz, A and B together = 6 kHz, switch contact = 30 Hz debounced, 2-channel rotary pulse generator = 8 kHz;	
Counting delay	: 100 μ s when reset; 20 ms when programming another preselection	
Min. pulse width	: electronic pulse 50 μ s, switch contact 5 ms	
External reset	: min. pulse width 10 ms	
Transmitter-supply	: 8 V DC controlled (Namur), 24 V DC (npn), Ri approx. 150 Ω , max. 50 mA (25 mA with 4 Relais outputs)	

Display

LED red, 14.2 mm	: LED red, 14.2 mm
Indicating range	: -99999 ... 999999 digit with leading zero suppression
Additional display	: LED 2-digit red, 7mm (parameter - and output indicator)

Output

Relay	: SPDT < 250 V AC < 250 VA < 2 A, < 300 V DC < 50 W < 2 A
Transistor	: max. 35 V AC/DC, 100 mA, with short circuit protection
Analog output	: 0/4 ... 20 mA burden $\leq 500 \Omega$; 0/2 ... 10V burden > 500 Ω , isolated Automatic output changing (burden dependent)
-Accuracy	: 0.1 %; TK 0.01 %/K

Case

Dimensions	: Panel case DIN 96x48 mm, material PA6-GF; UL94V-0
Weight	: Front 96x48 mm, mounting depth 100 mm, max. 390 g
Electrical connection	: Clamp terminals, 2 mm ² single wire, 1,5 mm ² flexible wire, AWG14
Protection	: Front IP65, terminals IP20, finger safe acc. German BGV A3

Dimension

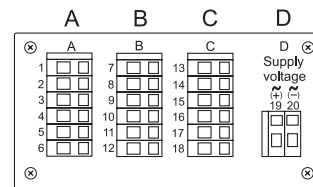
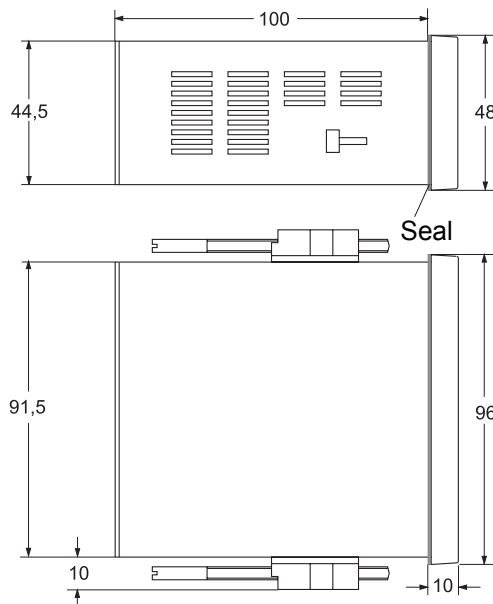

Position terminal strips

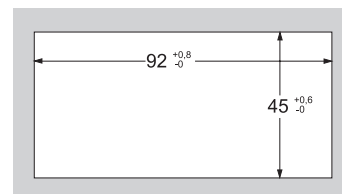

Panel cut-out
acc. to DIN 43700-96x48

Connection diagrams

Terminal strip A

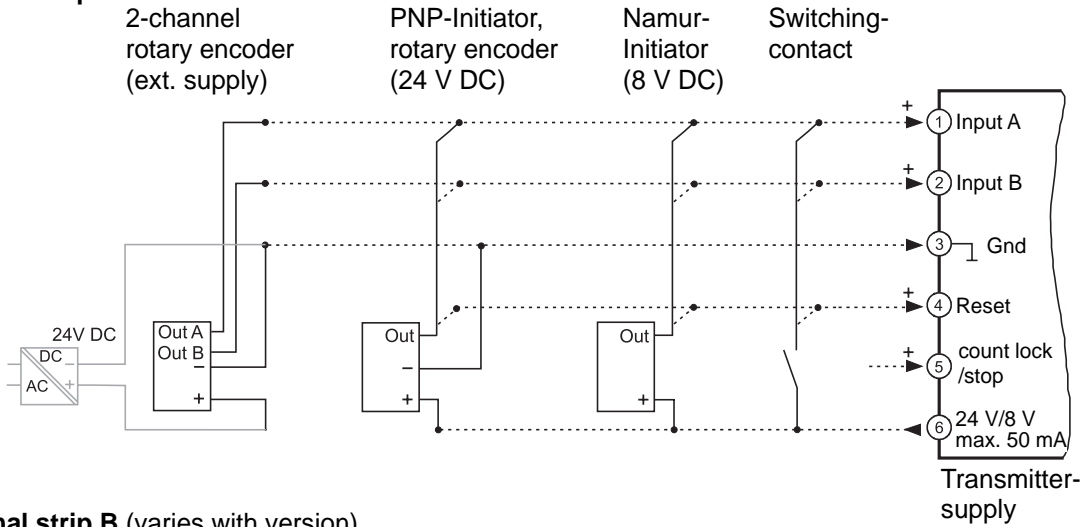

Terminal strip B (varies with version)

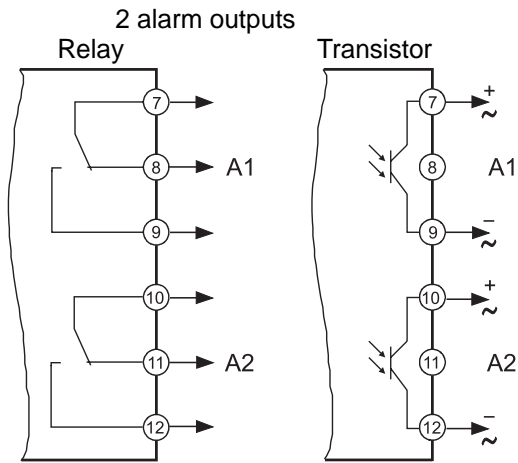

Terminal strip C (varies with version)

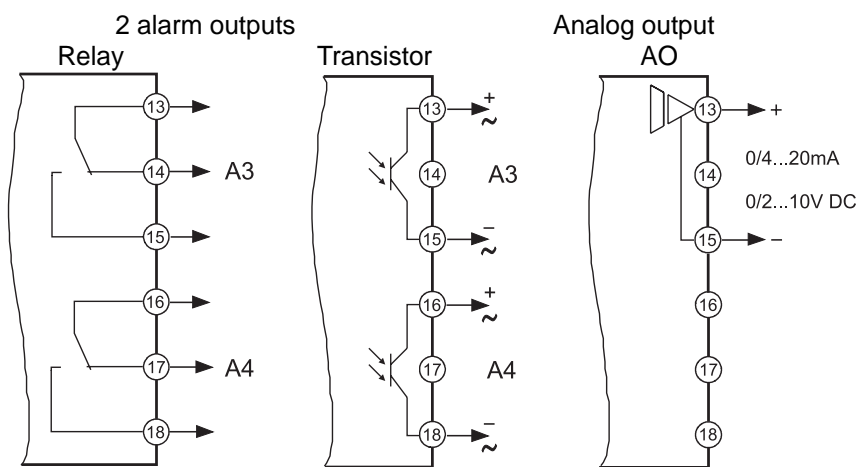

Terminal strip D supply voltage (varies with version)

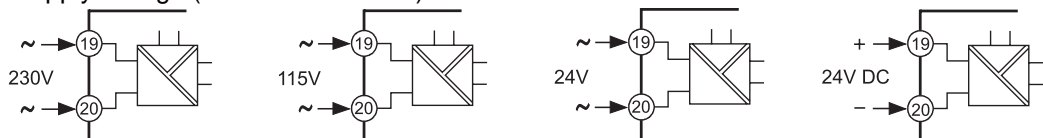

Controls and indicators

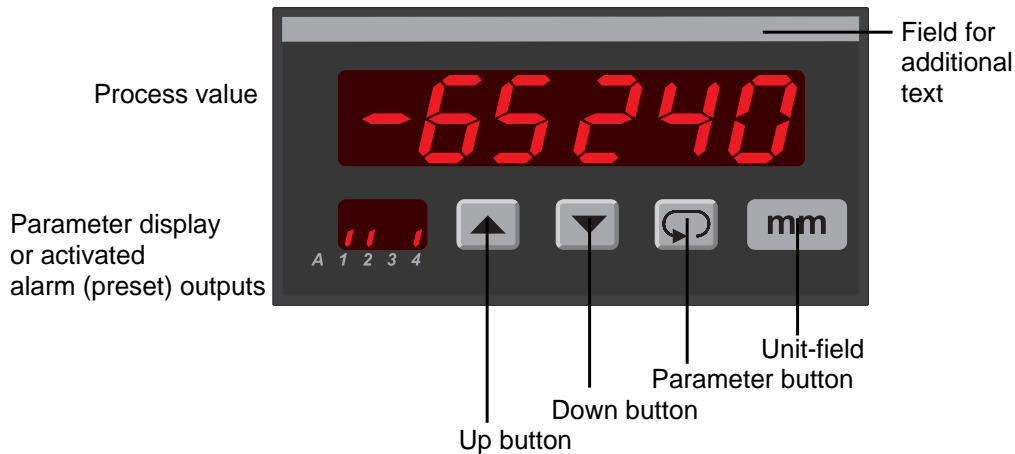

Descriptions

Operating of the device is arranged in 2 levels. The requested parameter can be called by button . For selections within a parameter or for entering data, use buttons and .

Button combinations:

- + + sets counting value back to the start value (5 t).
- + 1 parameter back.
- + sets parameter to zero or minimum value.

After power-on, the device is located in the **Working level**.
Set points of alarm outputs can be programmed if available.

Pressing the button for more than 2 seconds, activates the **Configuration level**. Now all the parameters which define the function of the device can be programmed. These are measuring input, input configuration, display conversion and switching performance of the alarm outputs and analog output.

After finishing the configuration or when longer than 2 minutes no button was pushed, the program jumps back to the working level. Leaving the configuration level is possible at any time when pushing the button .

Error codes:

PE Reading this symbol in the parameter display a parameter failure has been occurred. The display flashes. When pushing one of the buttons the error code will be deleted and the device is running with factory programmed parameters. Configuration and function of the device must be checked. If the error occurs again, please ship the device to factory for repair service.

Loc Programming lock active ⇒ see page 9

oF Overflow ⇒ see page 11

Start-up note: The device has to be configured, before it can be used (see page 6).

Notes to representation



Parameter is only displayed when configured

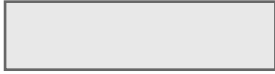

Parameter is only displayed when feature is included (see order code)

Please Note: All parameters can be called if they are not blocked by other programmed parameters and if they are available. **Factory settings** are shown in the display.

Working level

Button	Display	Description
		Count value Output indication (only if installed and activated).
		Setpoint output A1 Setting possible from -99999 ... 999999 digit with buttons ▲ and ▼.
		Setpoint output A2 Setting possible from -99999 ... 999999 digit with buttons ▲ and ▼.
		Setpoint output A3 Setting possible from -99999 ... 999999 digit with buttons ▲ and ▼.
		Setpoint output A4 Setting possible from -99999 ... 999999 digit with buttons ▲ and ▼.

Configuration

Button **Display** **Description** (Display graphic shows factory settings)

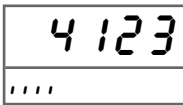

Working level

Press 2s

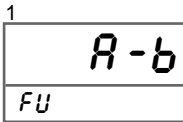

Function: input configuration A and B; count direction

A - b = A up, B down
A - b d b = A up, B down, for switching contacts
A u. b = A up, B up
A u. b d b = A up, B up, for switching contacts
90° | d = rotary encoder

Selection with buttons ▲ and ▼.

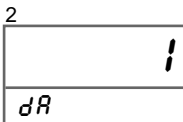

Prescaler input A

Setting possible from 1 ... 9999 digit with buttons ▲ and ▼.
 (Only every nth pulse is counted)

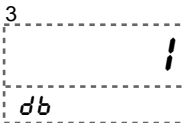

Prescaler input B

Setting possible from 1 ... 9999 digit with buttons ▲ and ▼.
 (Only every nth pulse is counted)

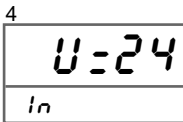

Transmitter supply/input level

U = 24 = 24 V DC for pnp-proximity switch
U = 8 = 8 V DC for Namur-proximity switch*
 (*with ext. 5 V supply also suitable for TTL signals)
t E 5 t = only for factory settings.

Selection with buttons ▲ and ▼.

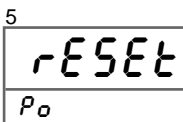

Count value at Power-on

r E 5 E t = loads start value (5 t) (see page 7)
r E 5 t o r = count value is stored if power fails

Selection with buttons ▲ and ▼.

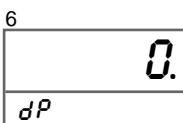





Number of decimal places











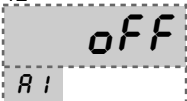



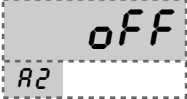

.000
.00
.0
0.

Selection with buttons ▲ and ▼.

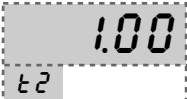

Continue page 7

Button	Display	Description (Display graphic shows factory settings)
↓	<div style="border: 1px solid black; padding: 2px; width: fit-content;"> ⁷ <div style="border: 1px solid black; padding: 2px; display: inline-block;"> ! </div> <i>d</i> </div>	Divisor for display Setting possible from <i>!</i> ... <i>9999</i> digit, with buttons ▲ and ▼. ⇒ also see page 11
		
↓	<div style="border: 1px solid black; padding: 2px; width: fit-content;"> ⁸ <div style="border: 1px solid black; padding: 2px; display: inline-block;"> ! </div> <i>F</i> </div>	Factor for display Setting possible from <i>!</i> ... <i>9999</i> digit, with buttons ▲ and ▼. ⇒ also see page 11
		
↓	<div style="border: 1px solid black; padding: 2px; width: fit-content;"> ⁹ <div style="border: 1px solid black; padding: 2px; display: inline-block;"> 0 </div> <i>5 t</i> </div>	Start value Count value after reset. Setting possible from <i>-99999</i> ... <i>999999</i> Digit with buttons ▲ and ▼.
		
↓	<div style="border: 1px solid black; padding: 2px; width: fit-content;"> ¹⁰ <div style="border: 1px solid black; padding: 2px; display: inline-block;"> off </div> <i>En</i> </div>	End value <i>off</i> : the counter operates as totalizing counter in the full range range. When reaching the value <i>-99999</i> or <i>999999</i> , the counter stops. In the case of overflow the display flashes. <i>on</i> : the counter operates as ring counter between start value <i>5 t</i> and end value <i>En</i> . (see following parameter). Selection with buttons ▲ and ▼.
		
↓	<div style="border: 1px dashed black; padding: 2px; width: fit-content;"> ¹¹ <div style="border: 1px solid black; padding: 2px; display: inline-block;"> 999999 </div> <i>En</i> </div>	Count value for internal reset Setting possible from <i>-99999</i> ... <i>999999</i> digit with buttons ▲ and ▼.
		

Button	Display	Description (Display graphic shows factory settings)
↓ 	12  R1	Switching performance alarm (preset) output A1 oFF = no output o n L (min) = continuous contact: on-off o n J (max) = continuous contact: off-on o n n = pulse contact: off-on-off o n u = pulse contact: on-off-on Selection with buttons ▲ and ▼.
		
↓ 	13  R1	Setpoint output A1 Setting possible from -99999 ... 999999 digit, with buttons ▲ and ▼.
		
↓ 	14  t1	Switching time output A1 [sec]. Setting possible from 0.01 ... 99.99 s, with buttons ▲ and ▼.
		
↓ 	15  R2	Switching performance alarm (preset) output A2 oFF = no output o n L (min) = continuous contact: on-off o n J (max) = continuous contact: off-on o n n = pulse contact: off-on-off o n u = pulse contact: on-off-on Selection with buttons ▲ and ▼.
		
↓ 	16  R2	Setpoint output A2 Setting possible from -99999 ... 999999 digit, with buttons ▲ and ▼.
		
↓ 	17  t2	Switching time output A2 [sec]. Setting possible from 0.01 ... 99.99 s, with buttons ▲ and ▼. Note: The parameter settings for A3 ... A4 have to be configured in the same way.
		

Button **Display** **Description** (Display graphic shows factory settings)

18

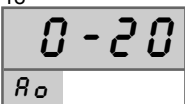
↓  **Analog output**
0 - 20 mA (0 - 10 V DC)
4 - 20 mA (2 - 10 V DC)
 The switch-over from current to voltage output is load dependent
 ($\leq 500 \Omega$ = current output, $> 500 \Omega$ = voltage output).
 Selection with buttons ▲ and ▼.

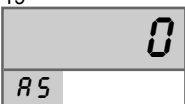

19

↓  **Start value for analog output**
 Setting possible from - 99999 ... 999999 Digit
 with buttons ▲ and ▼.

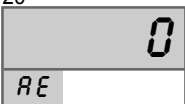

20

↓  **End value for analog output**
 Setting possible from - 99999 ... 999999 digit with buttons ▲ and ▼.

If the start value *R 5* > end value *R E* , the output works with decreasing characteristic.

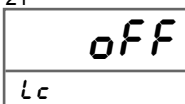

21

↓  **Parameter lock**
off = no lock
[onn. = configuration level locked
R L L = all parameters locked
[R L = only with analog output (only for factory settings)
 Selection with buttons ▲ and ▼.

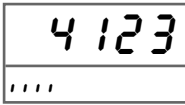

 **Return to the working level (count value)**

Linear counter

This counter can operate in the full range from -99999 up to 999999. Counting can start from any start value. Depending on up or down counter function the count value will increase or decrease. Maximum 2 alarm (preset) outputs can be activated either as continuous or pulse contact. Reset to the start value only with external reset.

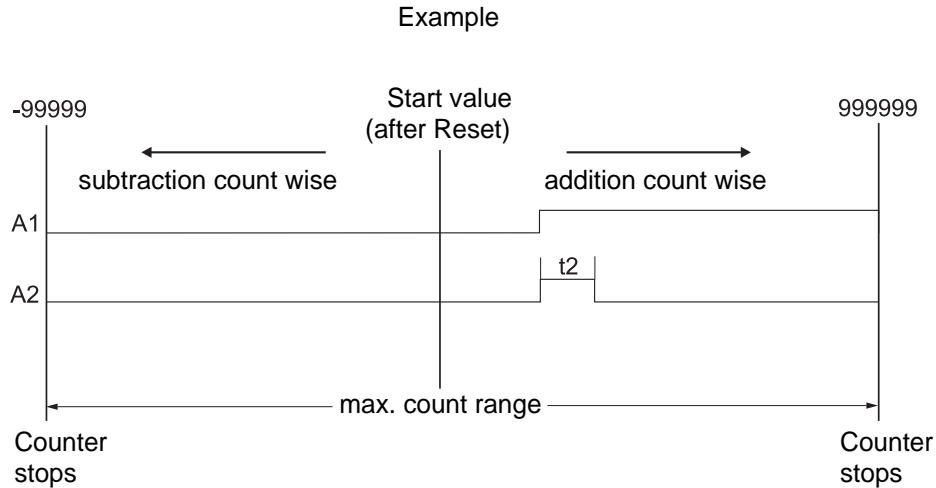

Ring counter

This counter operates in the range between start (Start) and end value (End) or reverse. The procedure repeats regularly unless the counting direction is reversed. Depending on the counting mode, the count value goes back from end value to start value or from start value to end value. 0° and 360° are identical in a circle. The start value and the end value coincide in the ring count mode.

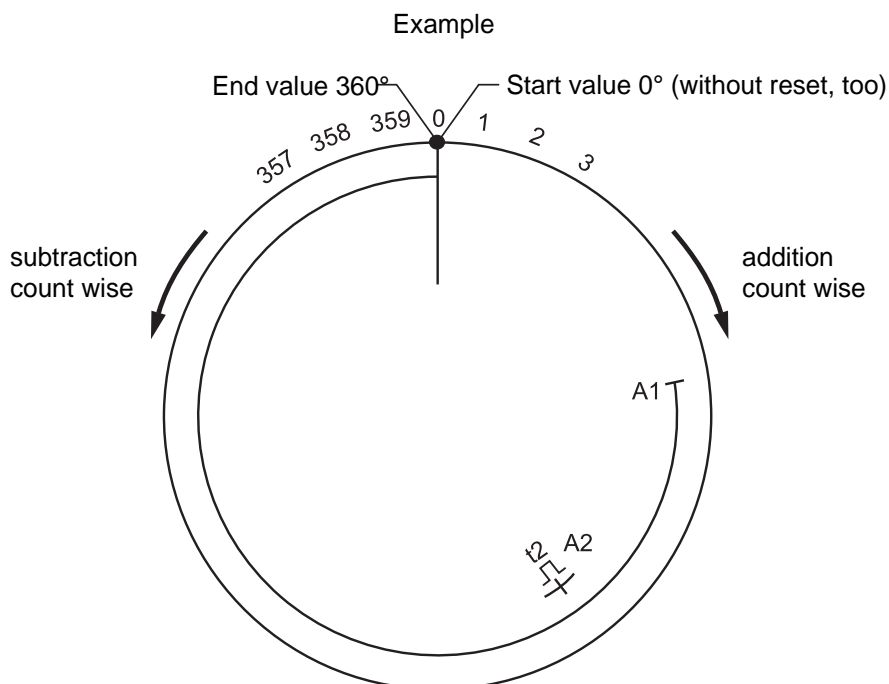

Display conversion

With certain settings of a divisor (d) and factor (F) it is possible that the counter does not work in the full range (0 ... 999999). The relationship is as following:

$$\text{Maximum display range} = \frac{8 \times 10^6 \times \text{factor } (F)}{\text{divisor } (d)} \quad \text{should be } > 999999$$

If the calculated value is less than 999999, the maximal counter value stops at this value. This can be avoided with the prescaler $d \ A$ respectively $d \ b$.

Example:

The flow rate in a measuring system shall be measured in m³ and displayed without decimal places.

The sensor generates every 0.084m³ one pulse.

For programming of the display conversion, the sensor constant has to be converted to a fraction first.

Therefore It follows:

$$\text{Sensor constant} = \frac{\text{Factor } (F) = 84}{\text{Divisor } (d) = 1000}$$

Please set for factor $F = 84$ and for divisor $d = 1000$. The check of the maximum display range shows:

$$\text{Maximum display range} = \frac{8 \times 10^6 \times 84}{1000} = 672000$$

This means, the counter can display maximum up to 672000 m³, when the counting stops. If this is insufficient, part of the divisors can be applied to prescaler $d \ A$ or $d \ b$ respectively. In this example if divisor d was reduced to 500, the maximum display range is > 999999 and full capacity of the counter will be reached.

The procedure is as following:

Set the divisor d to 500, the prescaler $d \ A$ respectively $d \ b$ (depending to the input) to 2.

The calculated value::

$$\text{Maximum display range} = \frac{8 \times 10^6 \times 84}{500} = 1344000$$

This provides an optimum configuration for the current example.

Ordering code

UZ9648 - 1. - 2. - 3. - 4. - 5. - 6. - 7.

1. Terminal strip A

1 2 configurable counting inputs,
extensive counting functions,
integrated transmitter-supply,
programmable display conversion,
reset input

2. Terminal strip B

00 not installed
2R 2 alarm outputs relay
2T 2 alarm outputs transistor

3. Terminal strip C

00 not installed
2R 2 alarm outputs relay
2T 2 alarm outputs transistor
AO Analog output 0/4 ... 20 mA or 0/2 ... 10 V DC
isolated

4. Terminal strip D supply voltage

0 230 V AC ± 10 % 50-60 Hz
1 115 V AC ± 10 % 50-60 Hz
4 24 V AC ± 10 % 50-60 Hz
5 24 V DC ± 15 %

5. Option

00 without option

6. Unit (on the panel front)

7. **Additional text** (on the additional text field on the panelmeter,
maximum 3 x 90mm WxH)