

Active-power transmitter WM 500

For 1- and 3-phase symmetric power supply systems

Features

- Current range 1 A or 5 A
- Frequency range 45 ... 400 Hz
- Power-factor ($\cos\varphi$) switch selectable 0.72 or 1
- Nominal accuracy 0.2 %
- Output 0/4 ... 20 mA or 0/2 ... 10 V switch selectable
- Final value adjustable -30 ... 5 %;
- Full 3-port isolation
- Supply voltage 230 V AC or 24 V DC
- 22.5 mm case for DIN rail mounting



General information

Active-power transmitter WM500 converts active-power of symmetric 1-3 phase power supply systems into proportional industry standard signals. Devices without compensating circuits can be used to measure active-power of phase-angle controlled equipments or electric motor drives controlled by frequency inverters. Devices with integrated compensating circuits (only for sinusoidal voltage) compensate errors which depends on different deviation from line voltages to nominal voltages. Both types work with any curve shape variations of measuring current.

Error compensation

In practice an additional error up to 3% can occur when 3-phase line voltages are not symmetrical. The WM500 with built-in compensating circuit* eliminates this error nearly completely.

*Note: The device with compensating circuit must be connected to the measuring voltage at any time of operation!

Example:

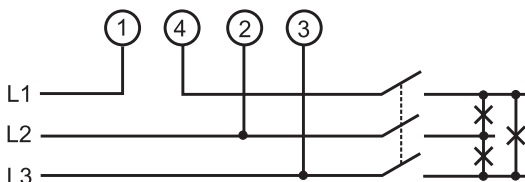

The results of the error compensation

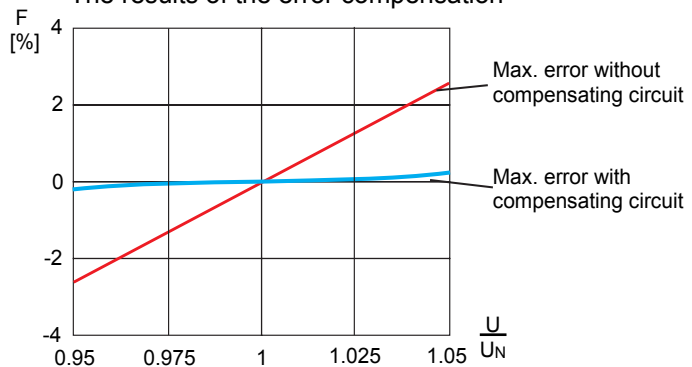

Deviation from line voltage to nominal voltage

Technical data

Power supply

Supply voltage	: 230 V AC \pm 10 %, 47 ... 63 Hz or 24 V DC \pm 15 %
Power consumption	: < 3 VA
Working temperature	: -10 ... 50 °C
Isolation voltage	: 500 V AC/DC acc. to VDE 0110 group 2 between input/output/supply voltage
Test voltage	: 4 kV DC between input/output/supply voltage
CE-conformity	: EN55022, IEC61000-4-3/4/5/11/13, EN60555

Input

Current input	: 0 ... 1 A : $R_i = 82 \text{ m}\Omega$, overload continue up to 2-times, 4-times max. 5 s 0 ... 5 A : $R_i = 10 \text{ m}\Omega$, overload continue up to 2-times, 4-times max. 5 s, frequency range : 45 ... 400 Hz, Crest-factor: 3 curve shape : insignificant
Voltage input	: 0 ... 440 V, $R_i = 3.4 \text{ k}\Omega/\text{V}$, overload max. 700 V frequency range : 45 ... 400 Hz curve shape : insignificant for device without compensating circuit curve shape : sinusoidal (3-phase) for device with compensating circuit
Final value	: adjustable -30 ... 5 %

Output

Programmable output voltage to current	: link between terminal 8 and 9
Current output	: 0/4 ... 20 mA, switch selectable, max. load $\leq 500 \Omega$
Voltage output	: 0/2 ... 10 V, switch selectable, max. load 10 mA
Adjustment formula	: $P = U \times I \times \sqrt{3} \times \cos\phi = 20 \text{ mA (10 V)}$
Accuracy	: < 0.2 %
Temperature coefficient	: < 10 ppm/K
Rise time (T_{90})	: < 500 ms

Case	: standard case of polycarbonate 8020 UL94V-1
Weight	: approx. 200 g
Connection	: screw terminals with pressure plate, max. 2.5 mm ²
Protection	: case IP30, terminals IP20 finger safe acc. to German BGV A3

Front panel controls

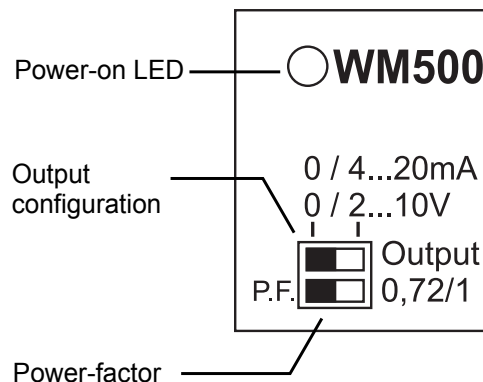

Connection diagrams

Inputs

Direct access, 1-phase

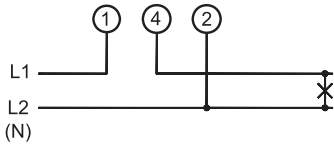

Direct access, 3-phase

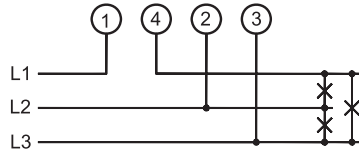

Current transformer connection

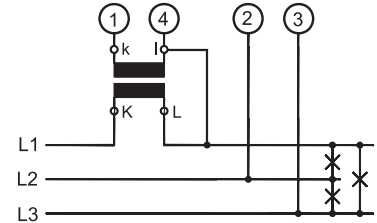

Voltage transformer connection

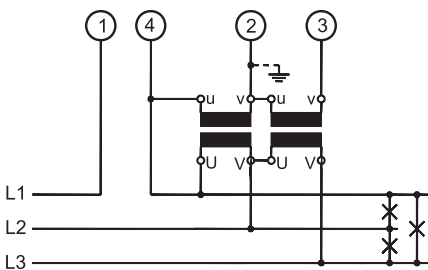

Current- and voltage transformer connection

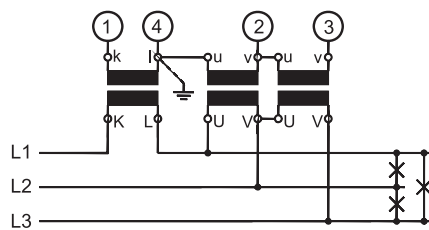

Output

Voltage output 0/2...10V
or current output 0/4...20mA

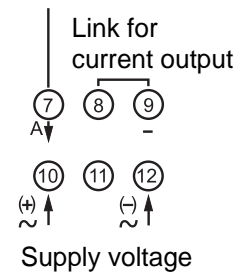

Dimensions

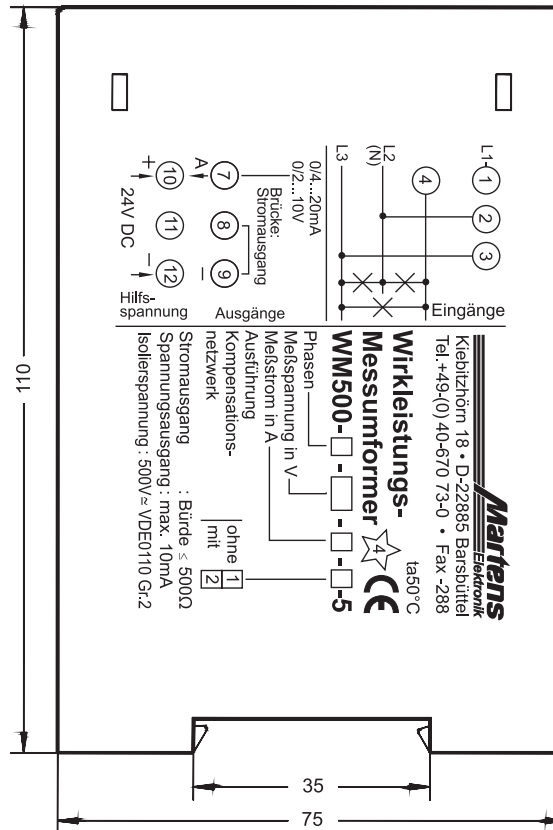
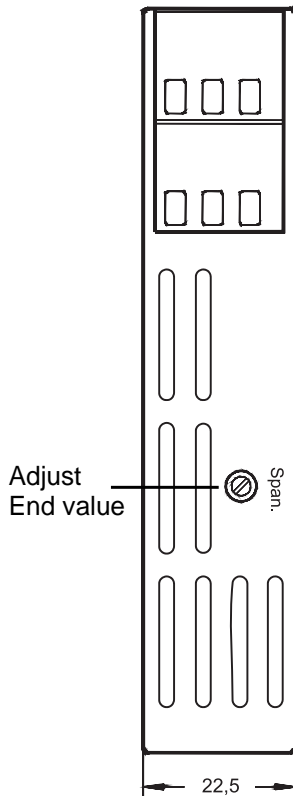

Caution!
Mounting of multiple units without distance is only permitted in horizontal orientation.

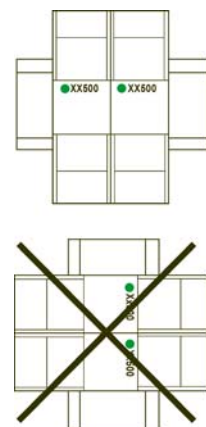

TS35 DIN rail mounting
acc. to DIN 46277 and DIN EN 50022

Ordering code

WM500 - 1. - 2. - 3. - 4. - 5.

1. Power supply system

- 1 1-phase
- 3 3-phase

2. Input voltage

- 100 100 V AC
- 110 110 V AC
- 230 230 V AC
- 400 400 V AC
- 440 440 V AC

3. Input current

- 1 1 A AC
- 5 5 A AC

4. Model

- 1 without compensating circuit (voltage curve shape insignificant)
- 2 with compensating circuit (voltage curve shape sinusoidal, only 3-phase)

5. Supply voltage

- 0 230V AC $\pm 10\%$
- 5 24V DC $\pm 15\%$
- Other supplies on request

Note!

Please quote the active-power measurement range and transformation ratio of the current transformer.